



2025-2026 PRODUCT RANGE



CHANDLER
GLASS & PACKAGING

BOTTLES / BOTTLE CUSTOMISATION / VCAPS / CARTONS / PARTITIONS

LET'S GET PERSONAL!

Create a personalised bottle with Chandler and craft an asset that helps your brand stand out from the crowd!

From an embossed or debossed logo to a completely unique design and shape, Chandler is here to help guide you through the process.



CHANDLER GLASS & PACKAGING PRODUCT RANGE



BOTTLES

We specialise in providing a competitively priced range of extra-light, mid to heavyweight premium BVS wine bottles. Additionally, we offer a comprehensive suite of services including:–

- Permanent decorations applied at the source, such as ceramic screen printing and foil decals
- Shoulder or body embossing, debossing of logos and patterns
- Bespoke bottle shapes and unique bottle design
- Premium and super premium (heavy) cork mouth wine bottles
- Bottles that are no longer readily available, including many cork mouth models that may have been phased out.

DECORATED VCAPS

We are able to provide all standard cap lengths and diameters, but our company focus and expertise is on 30H60 caps used for the sealing of premium wines. The top & side decoration possibilities are invigorating design innovation. They include:–

- Foil tipped top-embossing
- Fixed position top-embossing
- Side-emboss with the option to side-shave of the raised tips
- Distortion printed flat sheet for direct punch techniques
- Top & side: Screen printing / Off-set printing
- Top Litho printing CMYK
- Registered print application of 2x side screen print with 2x hot-foil decorations.

CUSTOMISED CARTONS

When you seek the extraordinary, our cartons will fit the bill. Our standard corrugate has a strength advantage over most. We specialise in providing:–

- Perfect register & reproduction of detailed graphic art files
- Highly decorated cartons that require Litho-print on coated and uncoated liners
- Large run pre-printed (roto-gravure) on coated and uncoated liners
- Hot-foil decorations
- Lay-down cartons for 6 & 12 bottles – double walled (5 layer paper)
- Hi-LPI-Flexo print
- Export grade B-Flute corrugate (USA & Canada)
- Single & double carry packs – and gift boxes.

PARTITIONS

Whether they are called sections, partitions, dividers – they are used to separating bottles in 6 or 12 pack cartons. Chandler has developed an assortment of partitions from a selection of cardboard materials. These include:–

- B-Flute corrugate 6 & 12 packs at H170mm
- B-Flute corrugate 12 at H298mm
- C-Flute made to order
- Intergard (Grey Card) 6 & 12 packs
- Lay-down moulded trays for 6 bottles.

BOTTLE CUSTOMISATION WITHIN EASY REACH



CHANDLER GLASS & PACKAGING

T: +64 9 448 1288 · E: info@chandler.co
 PO Box 303-237, North Harbour,
 Auckland 0751, New Zealand.
 www.chandler.co

CHANDLER GLASS & PACKAGING

Chandler Glass & Packaging (Chandler), established in 2007, specialises in coordinating and quality-controlling the supply of packaging solutions to wine producers. We provide standard & personalised wine bottles, decorated Vcap screwcaps, customised cartons, and an array of bottle partitions. Our services extend to wine producers in the United States and Australia.

Chandler's principal aim is to provide winemakers and wine marketers with a broader range of choices and enhanced dependable quality. As a dynamic enterprise, we pride ourselves on our resourcefulness and agility, consistently adapting to the evolving landscape of wine branding by offering innovative packaging solutions that challenge traditional bottling norms.

We are committed to delivering exemplary service and competitive pricing to our clients, ensuring bottle performance and visual quality are never compromised.

Chandler coordinates the production and supply of over 100 million wine bottles annually for wine producers across three markets and holds the position of the second-largest supplier of bottles and 30 x 60 screwcaps to New Zealand producers.

In our initial years of operation, we developed an extensive range of moulds for BVS, sparkling, and cork mouth bottles of varying weights and forms. Our focus extends beyond aesthetic and cosmetic considerations to include the stringent controls necessary to achieve a high-performing BVS mouth finish and flat label-panels. Through these efforts, we have contributed to raising the general standard of wine bottles in New Zealand and have elevated the quality and performance expectations of bottlers for essential dry goods.

WHAT CHANDLER DOES:

At Chandler, our dedicated team of online quality control personnel operates 24/7, meticulously monitoring output across every production line at our manufacturers' facilities. By rigorously measuring and inspecting production against established quality control parameters before packaging, we ensure that only conforming bottles are shipped to you.

Simultaneously, our experienced New Zealand-based team works closely with your planning personnel to guarantee timely and complete delivery of your required dry-goods.

For all your wine packaging needs, please contact us.

Sincerely, **The Chandler Team.**



BESPOKE WINE BOTTLES



PROPRIETARY OR
SPECIAL SURFACE



BESPOKE FORM + SIDE
DEBOSS BELT WITH
EMBOSSSED TEXT



SHOULDER EMBOSS TO
STANDARD FORM



BOTTLE FORM
INNOVATION

WINE BOTTLE DECORATIONS



MULTI-COLOUR DECORATION
& TWO HOT-FOIL STAMP

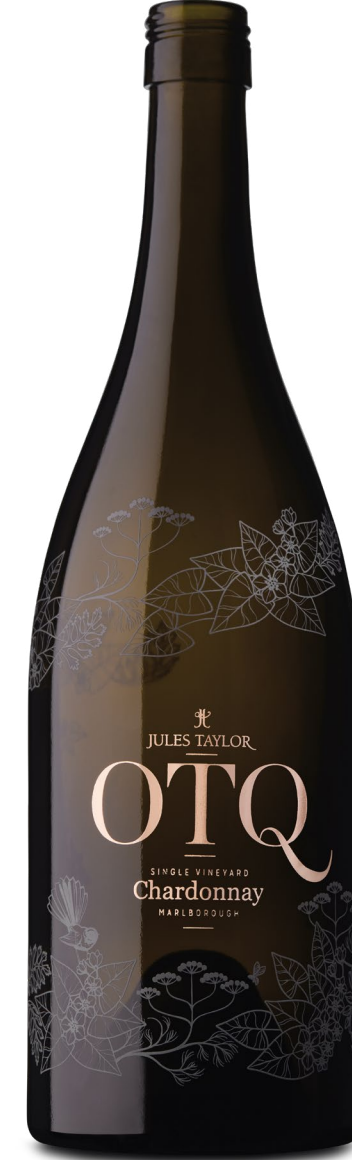

SCREEN PRINT WRAP
DECORATION + HOT-FOIL STAMP



MULTI-COLOUR SCREEN
PRINT DECORATION



SCREEN PRINT DECORATION
+ HOT-FOIL STAMP

* Manufacturers' bottle examples.

BURGUNDY BVS RANGE



BORDEAUX BVS RANGE



BURGUNDY CORK RANGE



BORDEAUX CORK RANGE



FLUTE BVS RANGE



SPARKLING RANGE



● **Standard Range (STD).** These bottles are readily available in our New Zealand warehouse. Please enquire.

■ **Ship to Order (STO).** These bottles are normally held as inventory at the glass factory and are only shipped against receipt of a firm client purchase order. The delivery lead-time for this category of bottle is an additional 10 weeks to the standard range.

△ **Made to Order (MTO).** These bottles are **NOT** normally held as inventory at the factory. Stock is only produced if combined client orders reach the MOQ of 300k units. Some are run 1-4 times a year so please enquire.

* = Reverse Taper

Pallet Configuration

** = Reverse Taper & 6 Layers

All other pallets are 7 layers.

Not all bottles are shown, please refer to the following table for availability.

WINE BOTTLE RANGE: BOTTLING SEASON 2025–2026



- Standard inventory
- Shipped to Order
- △ Made to Order (MOQ)



COLOURS AVAILABLE				CODE	DESCRIPTION	VOL mL	MOUTH	FILL POINT	WEIGHT	HEIGHT	DIAMETER	LABEL STR.	PALLET LOAD	
ANT				BURGUNDY BVS									OPTIMAL	
△	△	△	△	CR4087	BURGUNDY MINUIT	187	BVS 25 x 43	25.0mm	150g	174mm	53.8mm	45.5mm	2,706	
●	△	△	△	CR4037	BURGUNDY BAMBINO	375	BVS 30 x 60	35.0mm	305g	242mm	66.0mm	67.0mm	1,188	
●	△	△	△	CR402	BURGUNDY WHIPPET	750	BVS 30 x 60	35.0mm	358g	297mm	78.0mm	106.0mm	1,407	
●	●	■	●	CR402	BURGUNDY ARIA	750	BVS 30 x 60	35.0mm	385g	297mm	79.0mm	103.0mm	1,407	
●	■	△	△	CR404	BURGUNDY LEGERE SH	750	BVS 30 x 60	35.0mm	417g	297mm	80.0mm	103.0mm	1,407	
■	△	△	△	CR403	BURGUNDY EXPORT	750	BVS 30 x 60	35.0mm	477g	298mm	80.0mm	108.0mm	1,407	
●	△	△	△	CR4012	BURGUNDY PREMECO SH	750	BVS 30 x 60	35.0mm	487g	295mm	85.0mm	79.0mm	1,225	
●	△	△	△	CR408	BURGUNDY PREMIER SH	750	BVS 30 x 60	35.0mm	552g	296mm	85.8mm	79.0mm	1,225	
△	△	△	△	CR401	BURGUNDY TRADITIONAL SH	750	BVS 30 x 60	35.0mm	552g	298mm	81.5mm	99.5mm	1,358	
△	●	△	△	CR4015	BURGUNDY AVIGNON*	750	BVS 30 x 60	35.0mm	602g	300mm	87.4 / 80.8mm	77.0mm	1,183	
●	△	△	n/a	CR409	BURGUNDY GRANDEUR SH	750	BVS 30 x 60	35.0mm	672g	298mm	87.0mm	84.0mm	1,183	
△	△	n/a	n/a	CR4033	BURGUNDY OPTIMUS	1000	BVS 30 x 60	40.0mm	490g	317mm	86.8mm	114.0mm	1,225	
ANT				BORDEAUX BVS									OPTIMAL	
■	■	△	△	CR5037	BORDEAUX TOMTIT	375	BVS 30 x 60	35.0mm	280g	238.5mm	61.2mm	115.0mm	1,360	
△	△	△	△	CR502	BORDEAUX BANTAM	750	BVS 30 x 60	35.0mm	385g	295mm	74.5mm	144.7mm	1,624	
■	△	△	△	CR507	BORDEAUX PREMIUM EXPORT	750	BVS 30 x 60	35.0mm	507g	310mm	75.4mm	155.5mm	1,628	
△	△	△	△	CR508	BORDEAUX PREMIUM	750	BVS 30 x 60	35.0mm	577g	310mm	76.2mm	159.0mm	1,575	
△	△	△	△	CR5013	BORDEAUX POMEROL*	750	BVS 30 x 60	35.0mm	637g	307mm	82 / 75mm	147.0mm	1,372	
△	△	n/a	n/a	CR509	BORDEAUX ELITE**	750	BVS 30 x 60	35.0mm	692g	329.5mm	77.6 / 72mm	162.5mm	1,350	
△	△	n/a	n/a	CR5011	BORDEAUX RESOLUTE	750	BVS 30 x 60	35.0mm	692g	329mm	74.8mm	176.0mm	1,395	
ANT				HOCK / FLUTE BVS									OPTIMAL	
●	△	△	△	CR305	FLUTE IKO	750	BVS 30 x 60	35.0mm	385g	312mm	75.4mm	102.0mm	1,624	
●	●	△	△	CR301	FLUTE CERNAY	750	BVS 30 x 60	35.0mm	439g	329mm	75.0mm	97.0mm	1,392	

COLOURS AVAILABLE				CODE	DESCRIPTION	VOL mL	MOUTH	FILL POINT	WEIGHT	HEIGHT	DIAMETER	LABEL STR.	PALLET LOAD	
ANT				SPARKLING									OPTIMAL	
■	■	n/a	△	CR985	SPARKLING CARBECO	750	CROWN 29	82.0mm	618g	298mm	83.5mm	104.0mm	1,229	
△	■	△	△	CR981	SPARKLING CRÉMANT	750	CROWN 29	88.0mm	650g	277.5mm	91.2mm	80.0mm	1,050	
●	△	n/a	n/a	CR988	SPARKLING BEAUMONT	750	CROWN 29	78.0mm	795g	300mm	86.5mm	93.0mm	1,229	
■	△	n/a	n/a	CR983	SPARKLING BRUTUS	750	CROWN 29	94.0mm	880g	279mm	95.5mm	76.5mm	994	
ANT				BURGUNDY CORK MOUTH									OPTIMAL	
■	△	△	△	CR412	BURGUNDY LUMINARE	750	CORK 29	55.0mm	398g	296mm	81.0mm	96.0mm	1,407	
●	△	△	△	CR418	BURGUNDY LUCA	750	CORK 29	63.0mm	512g	295mm	84.7mm	80.0mm	1,225	
■	△	△	△	CR416	BURGUNDY TRADITIONAL C	750	CORK 29	63.5mm	525g	296mm	81.0mm	104.0mm	1,358	
●	△	△	△	CR429	BURGUNDY ALBI	750	CORK CAREÉ 31.5	63.0mm	580g	296.4mm	82.5mm	98.0mm	1,372	
△	△	n/a	n/a	CR419	BURGUNDY LOLA	750	CORK 29	63.5mm	640g	295mm	88.0mm	780mm	1,169	
■	△	n/a	n/a	CR441	BURGUNDY PLATO	750	CORK CAREÉ 33	63.0mm	695g	304.2mm	84.8mm	93.0mm	1,225	
ANT				BORDEAUX CORK MOUTH									OPTIMAL	
■	△	n/a	n/a	CR5113	BORDEAUX CLASSIQUE	750	CORK 29	63.5mm	482g	300.8mm	75.1mm	149.3mm	1,628	
△	△	n/a	n/a	CR5118	BORDEAUX MARGAUX	750	CORK 29	63.5mm	520g	300mm	76.0mm	149.0mm	1,575	
△	△	n/a	n/a	CR5112	BORDEAUX CICERO*	750	CORK 29	63.5mm	640g	308mm	82 / 75mm	143.5mm	1,372	
△	n/a	n/a	n/a	CR527	BORDEAUX STRATUS	750	CORK CAREÉ 31.5	63.5mm	695g	310mm	77.3mm	156.0mm	1,456	
■	△	n/a	n/a	CR519	BORDEAUX ELITE C**	750	CORK 29	63.5mm	695g	329.5mm	77.9 / 71.9mm	168.0mm	1,350	
■	n/a	n/a	n/a	CR529	BORDEAUX EMPEROR**	750	CORK CAREÉ 31.5	67.0mm	990g	312mm	86.3 / 77.6mm	160.0mm	1,054	
△	n/a	n/a	n/a	CR5312	BORDEAUX REPENT**	750	CORK CAREÉ 32	67.0mm	1200g	325mm	87.6 / 80.3mm	153.7mm	1,014	

There are as many as 20 additional Cork mouth bottles available – predominantly heavy weight. Please enquire.

- **Standard Range (STD).** These bottles are readily available in our New Zealand warehouse. Please enquire.
- **Ship to Order (STO).** These bottles are normally held as inventory at the glass factory and are only shipped against receipt of a firm client purchase order. The delivery lead-time for this category of bottle is an additional 10 weeks to the standard range.
- △ **Made to Order (MTO).** These bottles are **NOT** normally held as inventory at the factory. Stock is only produced if combined client orders reach the MOQ of 300k units. Some are run 1-4 times a year so please enquire.

* = Reverse Taper
Pallet Configuration
 ** = Reverse Taper & 6 Layers
 All other pallets are 7 layers.

Please enquire to find out more: info@chandler.co

18.7CL – 75CL BURGUNDY BVS¹

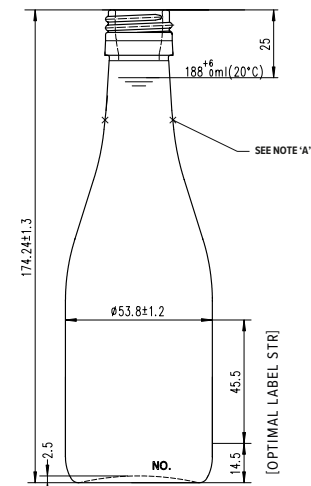

BURGUNDY MINUIT (187 ml)

PRODUCT CODE:	CR4087
MOUTH FINISH:	BVS 25 x 43
DIAMETER:	53.8mm ± 1.2mm
HEIGHT:	174.24mm ± 1.3mm
LABEL PANEL:	45.5mm
PUNT DEPTH:	2.5mm
WEIGHT:	150g
18.7cl FILL POINT:	25mm
PALLET LOAD:	2,706
LAYERS:	6

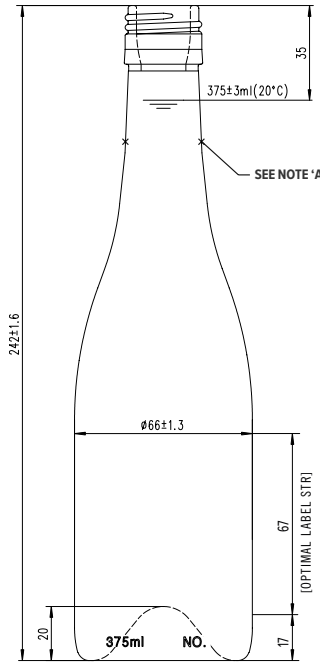

BURGUNDY BAMBINO (375 ml)

PRODUCT CODE:	CR4037
MOUTH FINISH:	BVS 30 x 60
DIAMETER:	66mm ± 1.3mm
HEIGHT:	242mm ± 1.6mm
LABEL PANEL:	67mm
PUNT DEPTH:	20mm
WEIGHT:	305g
37.5cl FILL POINT:	35mm
PALLET LOAD:	1,188
LAYERS:	4

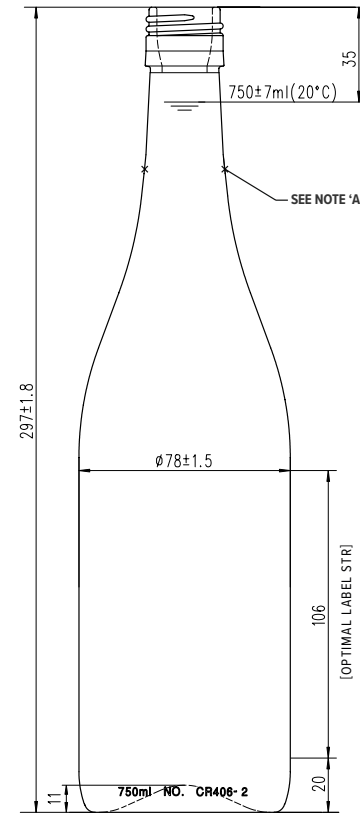

BURGUNDY WHIPPET

PRODUCT CODE:	CR406-2
MOUTH FINISH:	BVS 30 x 60
DIAMETER:	78mm ± 1.5mm
HEIGHT:	297mm ± 1.8mm
LABEL PANEL:	106mm
PUNT DEPTH:	11mm
WEIGHT:	358g
37.5cl FILL POINT:	35mm
PALLET LOAD:	1,407
LAYERS:	7

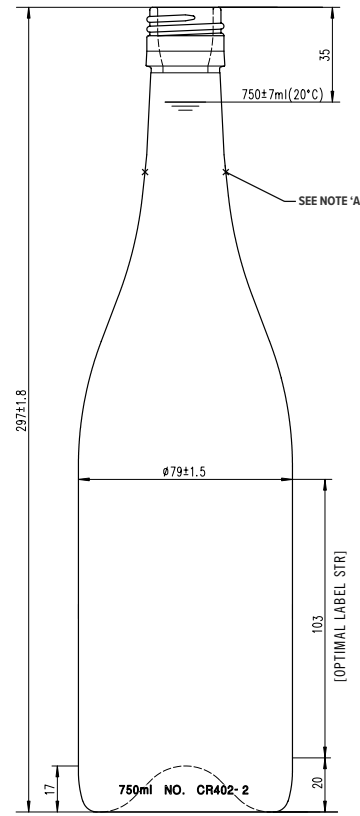

BURGUNDY ARIA

PRODUCT CODE:	CR402
MOUTH FINISH:	BVS 30 x 60
DIAMETER:	79mm ± 1.5mm
HEIGHT:	297mm ± 1.8mm
LABEL PANEL:	103mm
PUNT DEPTH:	17mm
WEIGHT:	385g
75cl FILL POINT:	35mm
PALLET LOAD:	1,407
LAYERS:	7

75CL – 100CL BURGUNDY BVS²

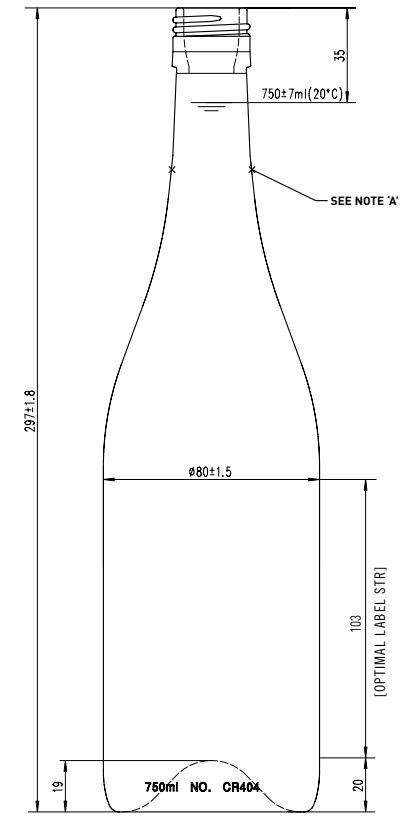

BURGUNDY LEGERE SH

PRODUCT CODE:	CR404
MOUTH FINISH:	BVS 30 x 60
DIAMETER:	80mm ± 1.5mm
HEIGHT:	297mm ± 1.8mm
LABEL PANEL:	103mm
PUNT DEPTH:	19mm
WEIGHT:	417g
75cl FILL POINT:	35mm
PALLET LOAD:	1,407
LAYERS:	7

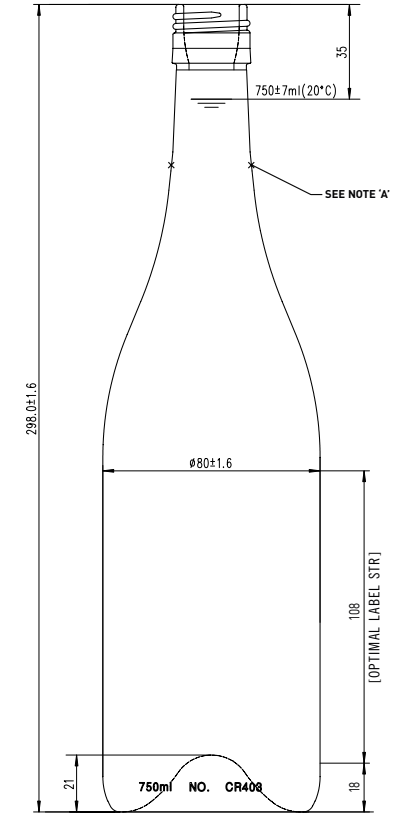

BURGUNDY EXPORT

PRODUCT CODE:	CR403
MOUTH FINISH:	BVS 30 x 60
DIAMETER:	80mm ± 1.6mm
HEIGHT:	298mm ± 1.6mm
LABEL PANEL:	108mm
PUNT DEPTH:	21mm
WEIGHT:	477g
75cl FILL POINT:	35mm
PALLET LOAD:	1,407
LAYERS:	7

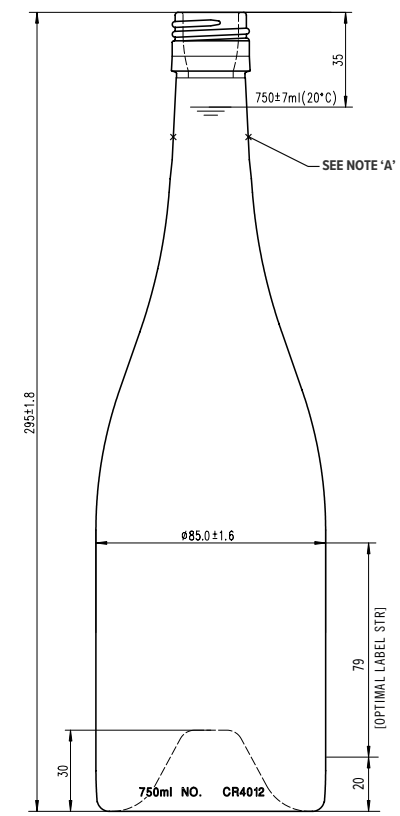

BURGUNDY PREMECO

PRODUCT CODE:	CR4012
MOUTH FINISH:	BVS 30 x 60
DIAMETER:	85mm ± 1.6mm
HEIGHT:	295mm ± 1.8mm
LABEL PANEL:	79mm
PUNT DEPTH:	30mm
WEIGHT:	477g
75cl FILL POINT:	35mm
PALLET LOAD:	1,225
LAYERS:	7

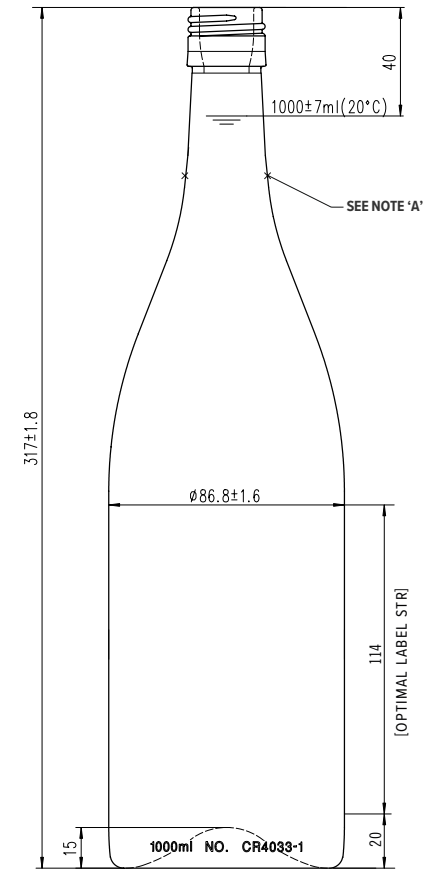

BURGUNDY OPTIMUS (1000 ml)

PRODUCT CODE:	CR4033
MOUTH FINISH:	BVS 30 x 60
DIAMETER:	86.8mm ± 1.6mm
HEIGHT:	317mm ± 1.8mm
LABEL PANEL:	114mm
PUNT DEPTH:	15mm
WEIGHT:	490g
100cl FILL POINT:	40mm
PALLET LOAD:	1,225
LAYERS:	7

NOTE A: CONTROLLED NECK & MOUTH REFER TO: DIMENSIONAL SPECIFICATIONS FOR BVS GLASS MOUTH FINISH – Norm: EN16293 (Refer to www.chandler.co)

NOTE A: CONTROLLED NECK & MOUTH REFER TO: DIMENSIONAL SPECIFICATIONS FOR BVS GLASS MOUTH FINISH – Norm: EN16293 (Refer to www.chandler.co)

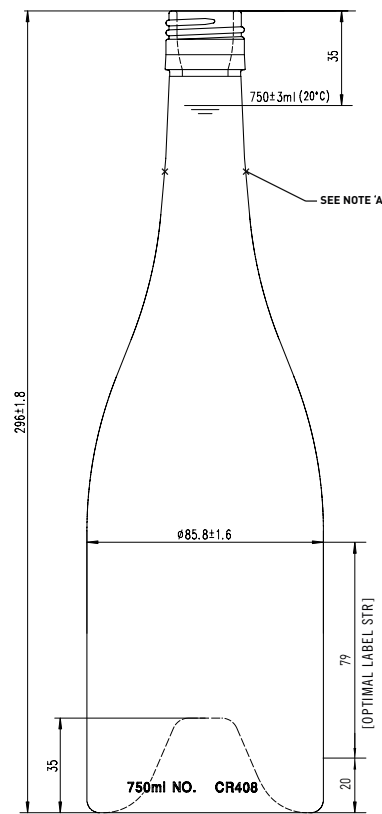

BURGUNDY PREMIER	
PRODUCT CODE:	CR408
MOUTH FINISH:	BVS 30 x 60
DIAMETER:	85.8mm ± 1.6mm
HEIGHT:	296mm ± 1.8mm
LABEL PANEL:	79mm
PUNT DEPTH:	35mm
WEIGHT:	552g
75cl FILL POINT:	35mm
PALLET LOAD:	1,225
LAYERS:	7

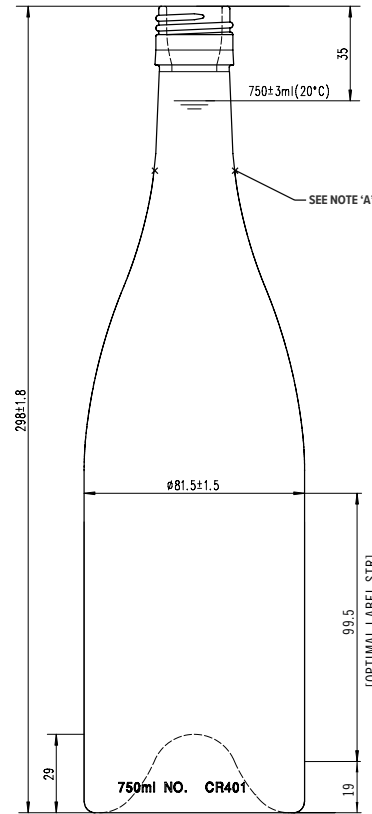

BURGUNDY TRADITIONAL	
PRODUCT CODE:	CR401
MOUTH FINISH:	BVS 30 x 60
DIAMETER:	81.5mm ± 1.5mm
HEIGHT:	298mm ± 1.8mm
LABEL PANEL:	99.5mm
PUNT DEPTH:	29mm
WEIGHT:	552g
75cl FILL POINT:	35mm
PALLET LOAD:	1,358
LAYERS:	7

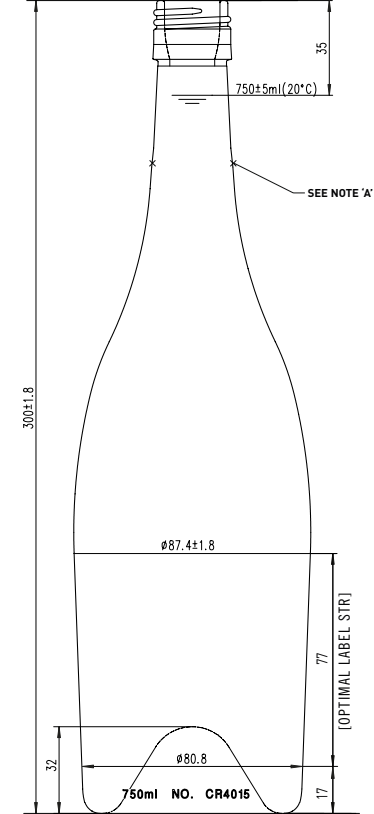

BURGUNDY AVIGNON	
PRODUCT CODE:	CR4015
MOUTH FINISH:	BVS 30 x 60
DIAMETER:	87.4 / 80.8mm
HEIGHT:	300mm ± 1.8mm
LABEL PANEL:	77mm
PUNT DEPTH:	32mm
WEIGHT:	602g
75cl FILL POINT:	35mm
PALLET LOAD:	1,183
LAYERS:	7

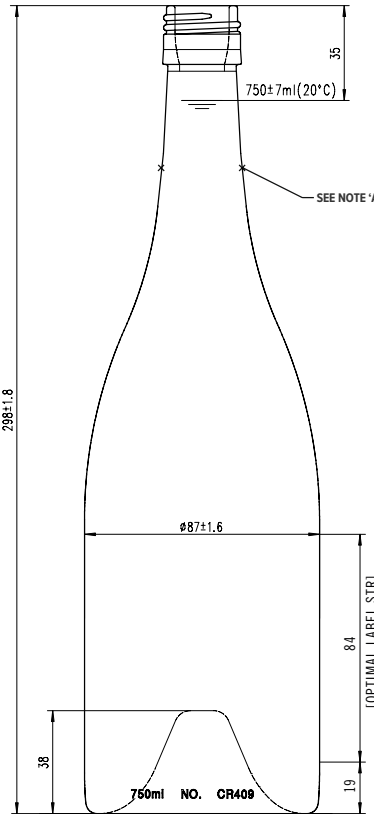

BURGUNDY GRANDEUR	
PRODUCT CODE:	CR409
MOUTH FINISH:	BVS 30 x 60
DIAMETER:	87.0mm ± 1.6mm
HEIGHT:	298mm ± 1.8mm
LABEL PANEL:	84mm
PUNT DEPTH:	38mm
WEIGHT:	672g
75cl FILL POINT:	35mm
PALLET LOAD:	1,183
LAYERS:	7

NOTE A: CONTROLLED NECK & MOUTH REFER TO: DIMENSIONAL SPECIFICATIONS FOR BVS GLASS MOUTH FINISH – Norm: EN16293 (Refer to www.chandler.co)

75CL BORDEAUX BVS¹

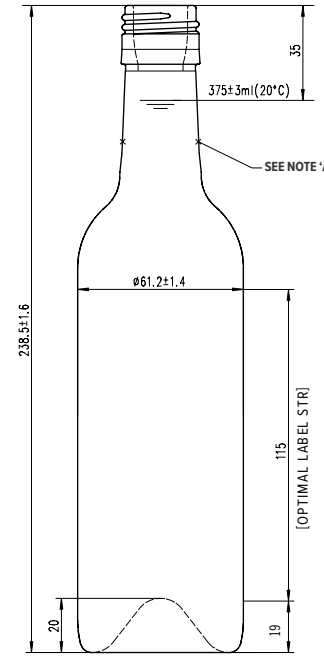

BORDEAUX TOMTIT (375 ml)

PRODUCT CODE:	CR5037
MOUTH FINISH:	BVS 30 x 60
DIAMETER:	61.2mm
HEIGHT:	238.5mm
LABEL PANEL:	115mm
PUNT DEPTH:	20mm
WEIGHT:	280g
75cl FILL POINT:	35mm
PALLET LOAD:	1,360
LAYERS:	4

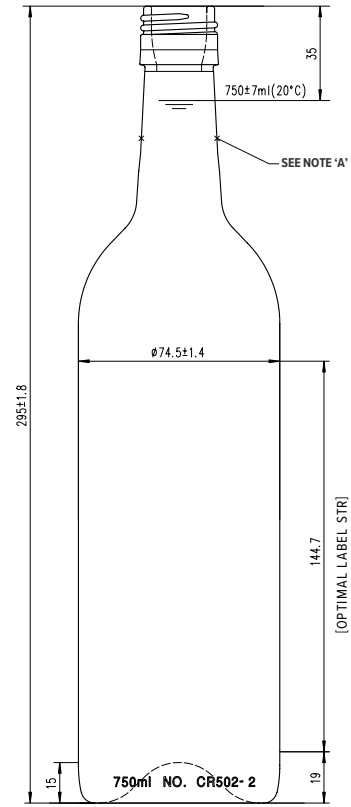

BORDEAUX BANTAM

PRODUCT CODE:	CR502
MOUTH FINISH:	BVS 30 x 60
DIAMETER:	74.5mm ± 1.4mm
HEIGHT:	295mm ± 1.8mm
LABEL PANEL:	144.7mm
PUNT DEPTH:	15mm
WEIGHT:	385g
75cl FILL POINT:	35mm
PALLET LOAD:	1,624
LAYERS:	7

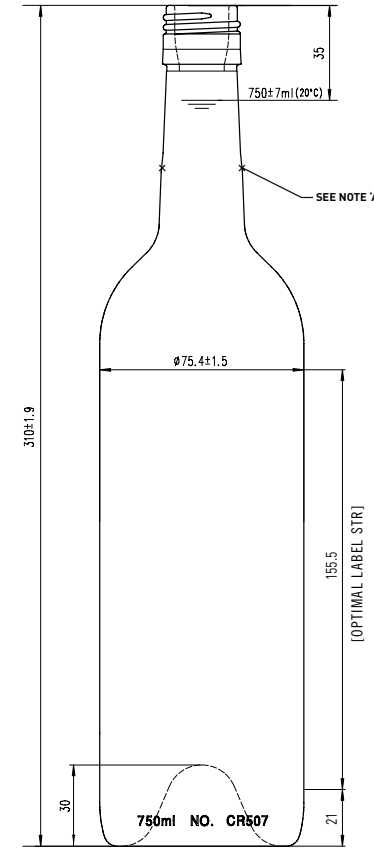

BORDEAUX PREMIUM EXPORT

PRODUCT CODE:	CR507
MOUTH FINISH:	BVS 30 x 60
DIAMETER:	75.4mm ± 1.5mm
HEIGHT:	310mm ± 1.9mm
LABEL PANEL:	155.5mm
PUNT DEPTH:	30mm
WEIGHT:	507g
75cl FILL POINT:	35mm
PALLET LOAD:	1,628
LAYERS:	7

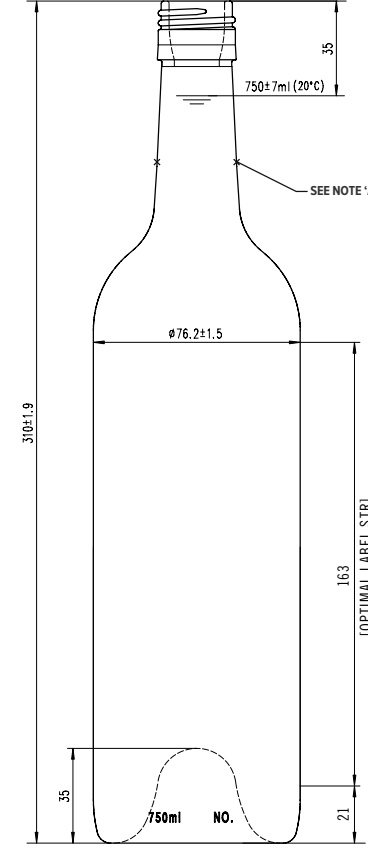

BORDEAUX PREMIUM

PRODUCT CODE:	CR508
MOUTH FINISH:	BVS 30 x 60
DIAMETER:	76.2mm ± 1.5mm
HEIGHT:	310mm ± 1.9mm
LABEL PANEL:	163mm
PUNT DEPTH:	35mm
WEIGHT:	577g
75cl FILL POINT:	35mm
PALLET LOAD:	1,575
LAYERS:	7

75CL BORDEAUX BVS²

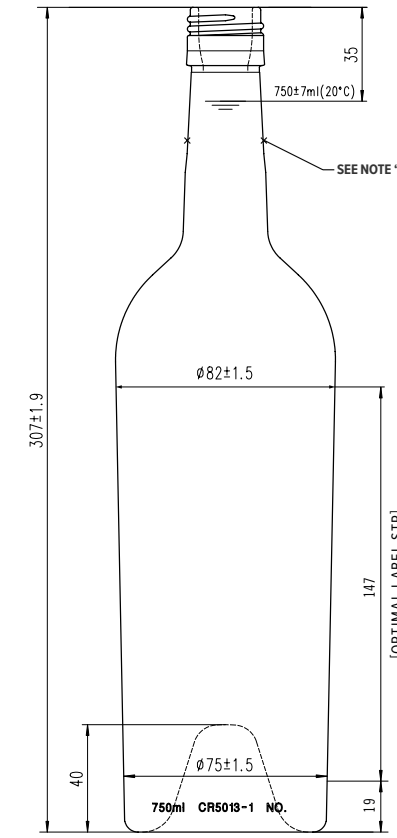

BORDEAUX POMEROL (TAPERED)

PRODUCT CODE:	CR5013
MOUTH FINISH:	BVS 30 x 60
DIAMETER:	Shoulder 82mm / Base 75mm
HEIGHT:	307mm ± 1.9mm
LABEL PANEL:	147mm
PUNT DEPTH:	40mm
WEIGHT:	637g
75cl FILL POINT:	35mm
PALLET LOAD:	1,372
LAYERS:	7

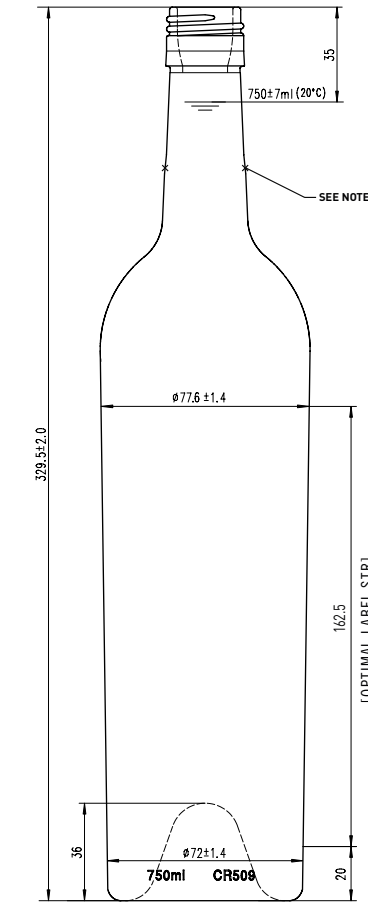

BORDEAUX ELITE (TAPERED)

PRODUCT CODE:	CR509
MOUTH FINISH:	BVS 30 x 60
DIAMETER:	Shoulder 77.6mm / Base 72mm
HEIGHT:	329.5mm ± 2mm
LABEL PANEL:	162.5mm
PUNT DEPTH:	36mm
WEIGHT:	692g
75cl FILL POINT:	35mm
PALLET LOAD:	1,350
LAYERS:	6

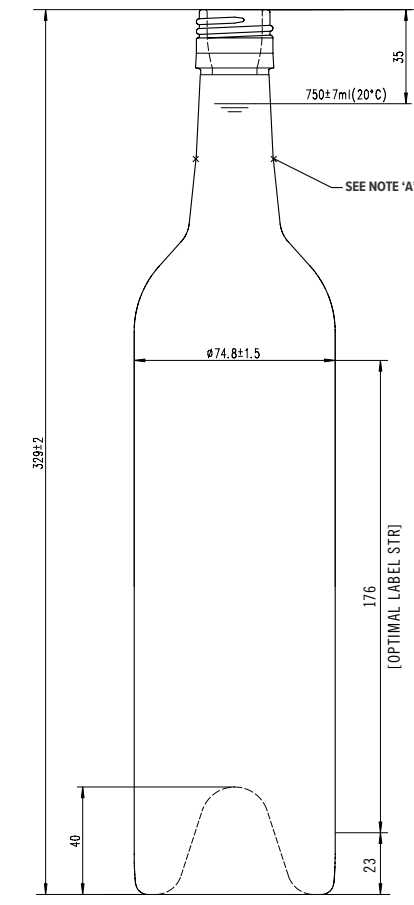

BORDEAUX RESOLUTE

PRODUCT CODE:	CR5011
MOUTH FINISH:	BVS 30 x 60
DIAMETER:	74.8mm ± 1.5mm
HEIGHT:	329mm ± 2mm
LABEL PANEL:	176mm
PUNT DEPTH:	40mm
WEIGHT:	692g
75cl FILL POINT:	35mm
PALLET LOAD:	1,395
LAYERS:	6

NOTE A: CONTROLLED NECK & MOUTH REFER TO: DIMENSIONAL SPECIFICATIONS FOR BVS GLASS MOUTH FINISH – Norm: EN16293 (Refer to www.chandler.co)

NOTE A: CONTROLLED NECK & MOUTH REFER TO: DIMENSIONAL SPECIFICATIONS FOR BVS GLASS MOUTH FINISH – Norm: EN16293 (Refer to www.chandler.co)

75CL HOCK / FLUTE BVS

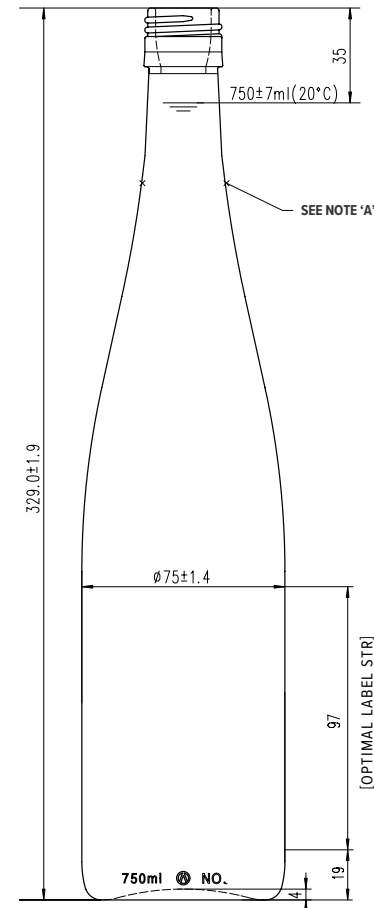
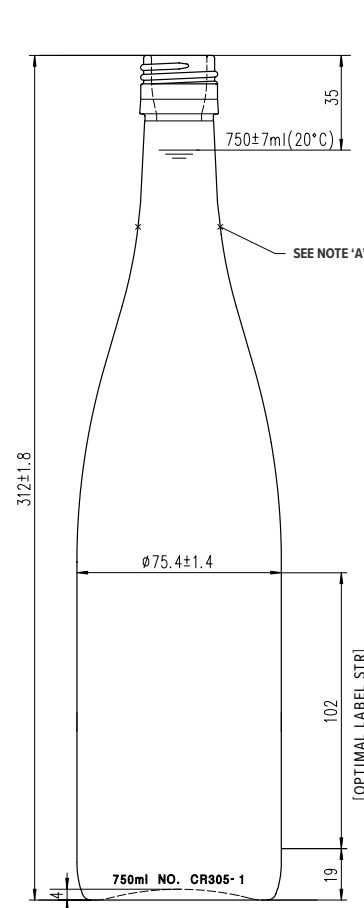

FLUTE IKO

PRODUCT CODE:	CR305
MOUTH FINISH:	BVS 30 x 60
DIAMETER:	75.4mm ± 1.4mm
HEIGHT:	312mm ± 1.8mm
LABEL PANEL:	102mm
PUNT DEPTH:	4mm
WEIGHT:	385g
75cl FILL POINT:	35mm
PALLET LOAD:	1,624
LAYERS:	7

FLUTE CERNAY

PRODUCT CODE:	CR301
MOUTH FINISH:	BVS 30 x 60
DIAMETER:	75.0mm ± 1.4mm
HEIGHT:	329mm ± 1.9mm
LABEL PANEL:	97mm
PUNT DEPTH:	4mm
WEIGHT:	439g
75cl FILL POINT:	35mm
PALLET LOAD:	1,392
LAYERS:	6

75CL SPARKLING

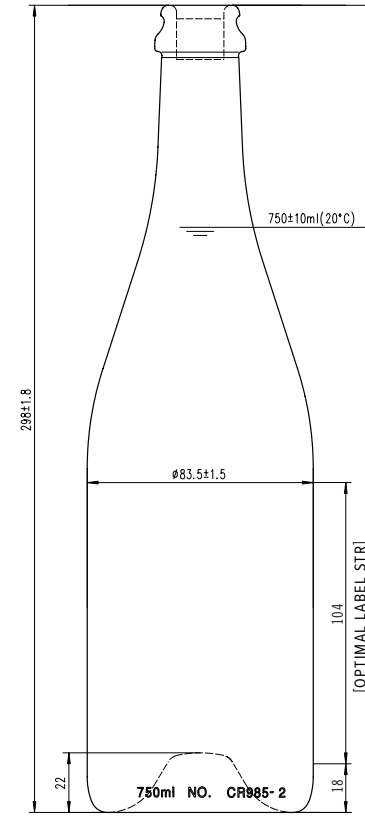

SPARKLING CARBECO

PRODUCT CODE:	CR985
MOUTH FINISH:	Crown 29mm
DIAMETER:	83.5mm ± 1.5mm
HEIGHT:	298mm ± 1.8mm
LABEL PANEL:	104mm
PUNT DEPTH:	22mm
WEIGHT:	618g
75cl FILL POINT:	82mm
PALLET LOAD:	1,229
LAYERS:	7

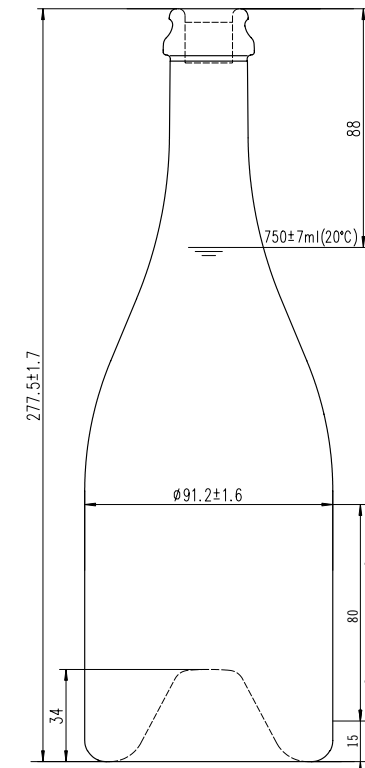

SPARKLING CRÉMANT

PRODUCT CODE:	CR981
MOUTH FINISH:	Crown 29mm
DIAMETER:	91.2mm ± 1.6mm
HEIGHT:	277.5mm ± 1.9mm
LABEL PANEL:	80mm
PUNT DEPTH:	34mm
WEIGHT:	650g
75cl FILL POINT:	88mm
PALLET LOAD:	1,050
LAYERS:	7

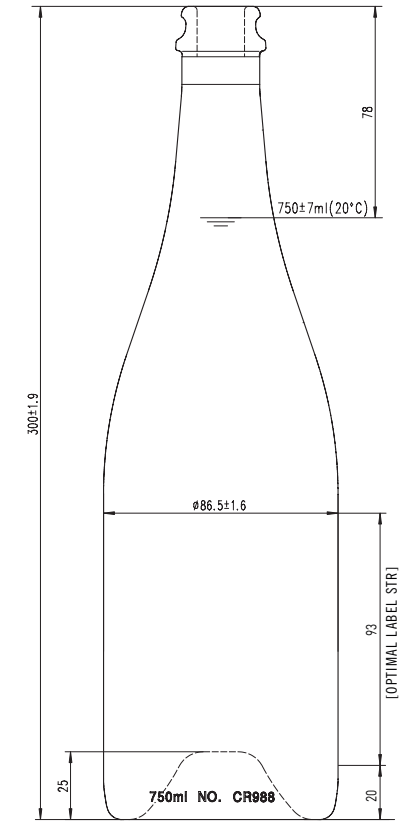

SPARKLING BEAUMONT

PRODUCT CODE:	CR988
MOUTH FINISH:	Crown 29mm
DIAMETER:	86.5mm ± 1.6mm
HEIGHT:	300mm ± 1.9mm
LABEL PANEL:	93mm
PUNT DEPTH:	25mm
WEIGHT:	795g
75cl FILL POINT:	78mm
PALLET LOAD:	1,229
LAYERS:	7

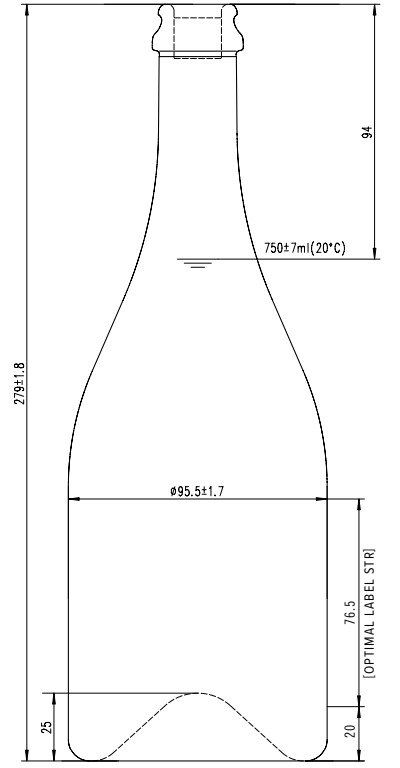

SPARKLING BRUTUS

PRODUCT CODE:	CR983
MOUTH FINISH:	Crown 29mm
DIAMETER:	95.5mm ± 1.7mm
HEIGHT:	279mm ± 1.8mm
LABEL PANEL:	76.5mm
PUNT DEPTH:	25mm
WEIGHT:	880g
75cl FILL POINT:	94mm
PALLET LOAD:	994
LAYERS:	7

NOTE A: CONTROLLED NECK & MOUTH REFER TO: DIMENSIONAL SPECIFICATIONS FOR BVS GLASS MOUTH FINISH – Norm: EN16293 (Refer to www.chandler.co)

75CL BURGUNDY CORK¹

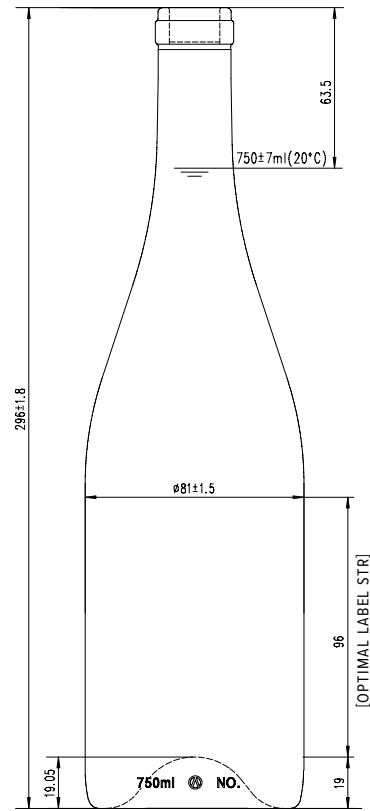

BURGUNDY LUMINARE

PRODUCT CODE:	CR412
MOUTH FINISH:	Cork 29
DIAMETER:	81.0mm ± 1.5mm
HEIGHT:	296mm ± 1.8mm
LABEL PANEL:	96mm
PUNT DEPTH:	19.05mm
WEIGHT:	395g
75cl FILL POINT:	63.5mm
PALLET LOAD:	1,407
LAYERS:	7

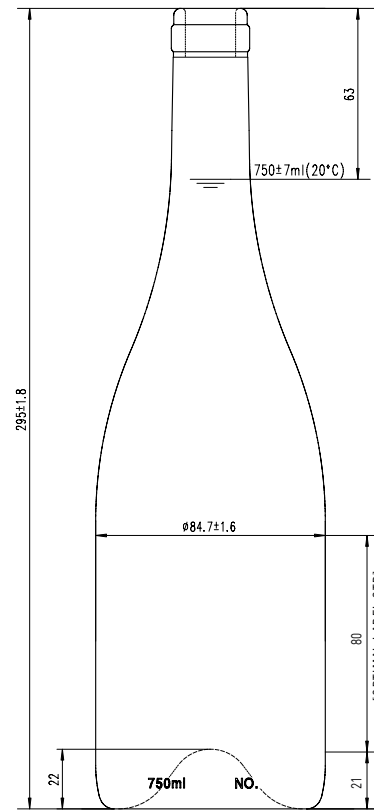

BURGUNDY LUCA

PRODUCT CODE:	CR418
MOUTH FINISH:	Cork 29
DIAMETER:	84.7mm ± 1.6mm
HEIGHT:	295mm ± 1.8mm
LABEL PANEL:	80mm
PUNT DEPTH:	22mm
WEIGHT:	512g
75cl FILL POINT:	63mm
PALLET LOAD:	1,225
LAYERS:	7

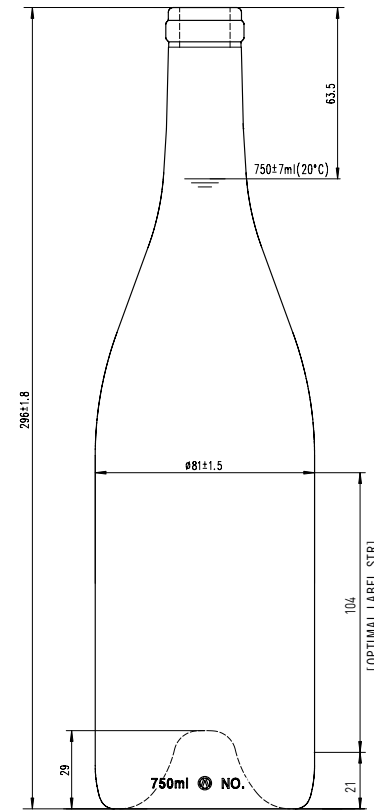

BURGUNDY TRADITIONAL C

PRODUCT CODE:	CR416
MOUTH FINISH:	Cork 29
DIAMETER:	81.0mm ± 1.5mm
HEIGHT:	296mm ± 1.8mm
LABEL PANEL:	104mm
PUNT DEPTH:	29mm
WEIGHT:	525g
75cl FILL POINT:	63.5mm
PALLET LOAD:	1,358
LAYERS:	7

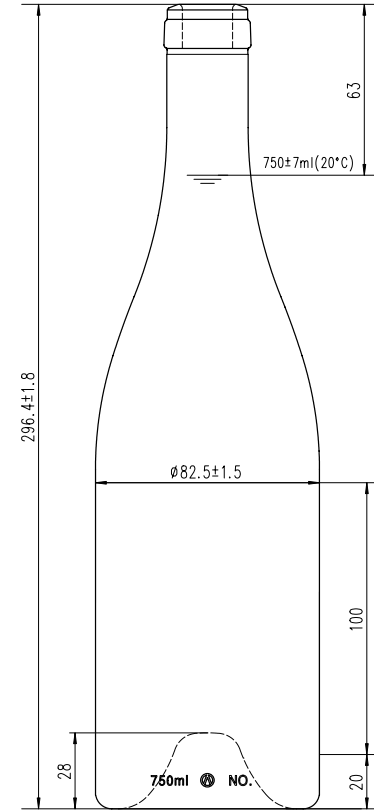

BURGUNDY ALBI

PRODUCT CODE:	CR429
MOUTH FINISH:	Cork 31.5 (Careé)
DIAMETER:	82.5mm ± 1.5mm
HEIGHT:	296.4mm ± 1.8mm
LABEL PANEL:	100mm
PUNT DEPTH:	28mm
WEIGHT:	580g
75cl FILL POINT:	63mm
PALLET LOAD:	1,372
LAYERS:	7

75CL BURGUNDY CORK²

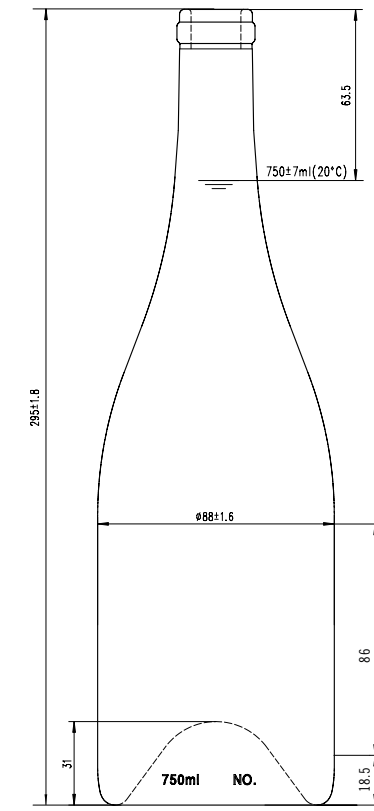

BURGUNDY LOLA

PRODUCT CODE:	CR419
MOUTH FINISH:	Cork 29
DIAMETER:	88.0mm ± 1.6mm
HEIGHT:	295mm ± 1.8mm
LABEL PANEL:	86mm
PUNT DEPTH:	31mm
WEIGHT:	640g
75cl FILL POINT:	63.5mm
PALLET LOAD:	1,169
LAYERS:	7

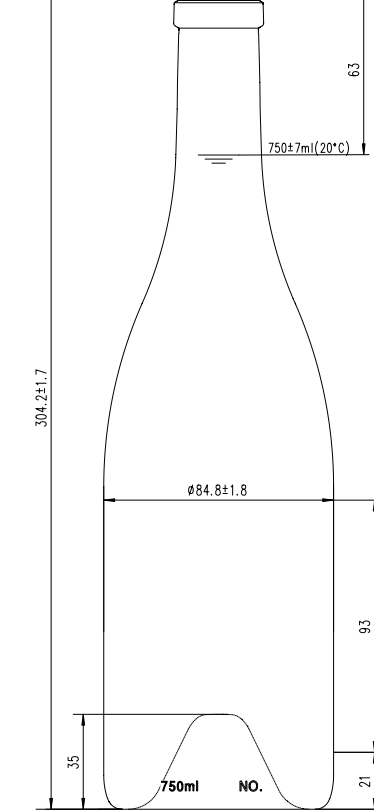

BURGUNDY PLATO

PRODUCT CODE:	CR441
MOUTH FINISH:	Cork 33 (Careé)
DIAMETER:	84.8mm ± 1.8mm
HEIGHT:	304.2mm ± 1.7mm
LABEL PANEL:	93mm
PUNT DEPTH:	35mm
WEIGHT:	695g
75cl FILL POINT:	63mm
PALLET LOAD:	1,225
LAYERS:	7

75CL BORDEAUX CORK¹

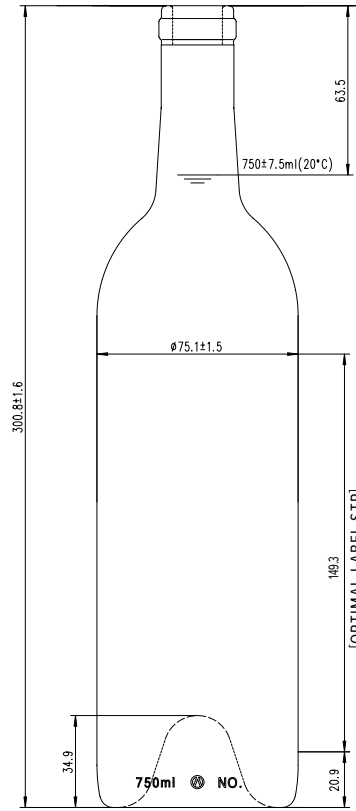

BORDEAUX CLASSIQUE

PRODUCT CODE:	CR5113
MOUTH FINISH:	Cork 29
DIAMETER:	75.1mm ± 1.5mm
HEIGHT:	300.8mm ± 1.6mm
LABEL PANEL:	149.3mm
PUNT DEPTH:	34.9mm
WEIGHT:	482g
75cl FILL POINT:	63.5mm
PALLET LOAD:	1,628
LAYERS:	7

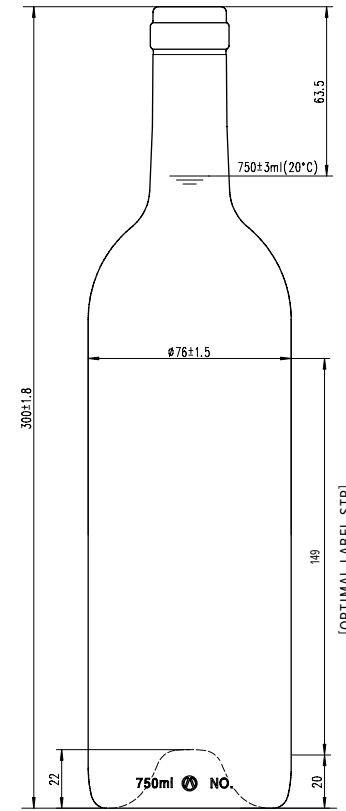

BORDEAUX MARGAUX

PRODUCT CODE:	CR5118
MOUTH FINISH:	Cork 29
DIAMETER:	76.0mm ± 1.5mm
HEIGHT:	300mm ± 1.8mm
LABEL PANEL:	149mm
PUNT DEPTH:	22mm
WEIGHT:	520g
75cl FILL POINT:	63.5mm
PALLET LOAD:	1,575
LAYERS:	7

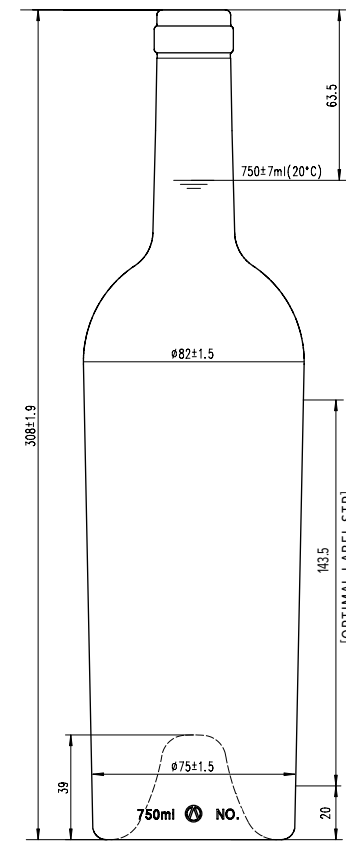

BORDEAUX CICERO (TAPERED)

PRODUCT CODE:	CR5112
MOUTH FINISH:	Cork 29
DIAMETER:	Shoulder 82mm / Base 75mm
HEIGHT:	308mm ± 1.9mm
LABEL PANEL:	143.5mm
PUNT DEPTH:	39mm
WEIGHT:	640g
75cl FILL POINT:	63.5mm
PALLET LOAD:	1,372
LAYERS:	7

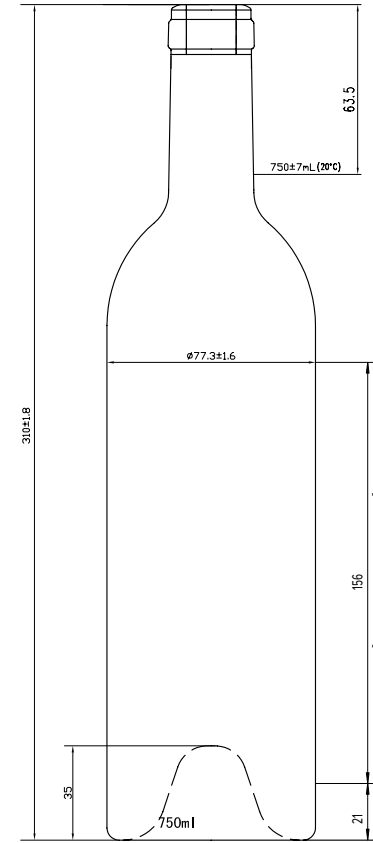

BORDEAUX STRATUS

PRODUCT CODE:	CR527
MOUTH FINISH:	Cork 31.5 (Careé)
DIAMETER:	77.3mm ± 1.6mm
HEIGHT:	310mm ± 1.8mm
LABEL PANEL:	156mm
PUNT DEPTH:	35mm
WEIGHT:	695g
75cl FILL POINT:	63.5mm
PALLET LOAD:	1,456
LAYERS:	7

75CL BORDEAUX CORK²

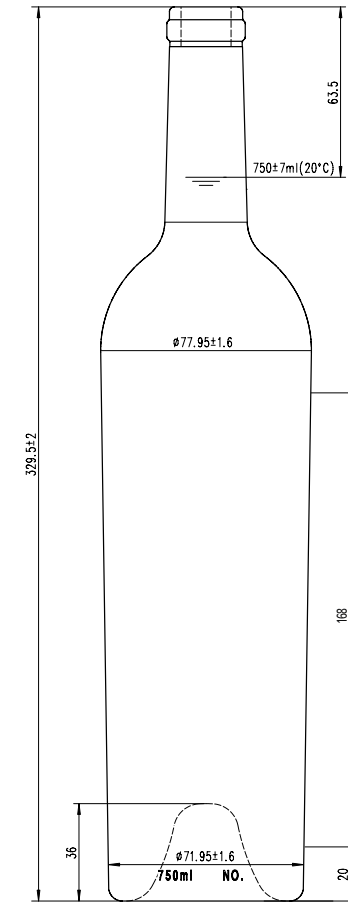

BORDEAUX ELITE C (TAPERED)

PRODUCT CODE:	CR519
MOUTH FINISH:	Cork 29
DIAMETER:	Shoulder 77.95mm / Base 71.95mm
HEIGHT:	329.5mm ± 2mm
LABEL PANEL:	168mm
PUNT DEPTH:	36mm
WEIGHT:	695g
75cl FILL POINT:	63.5mm
PALLET LOAD:	1,350
LAYERS:	6

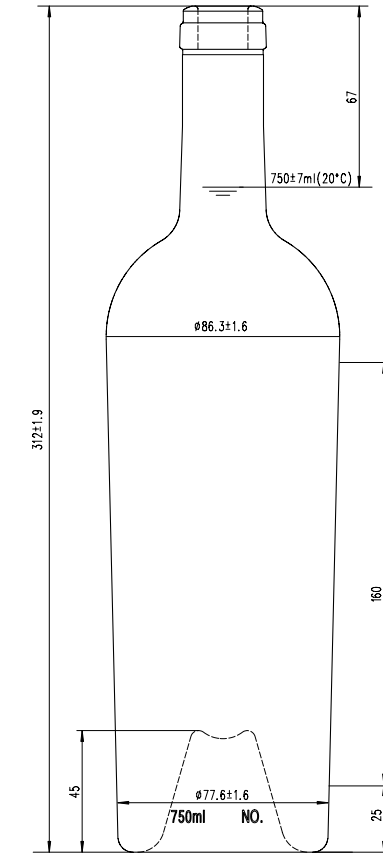

BORDEAUX EMPEROR (TAPERED)

PRODUCT CODE:	CR529
MOUTH FINISH:	Cork 31.5 (Careé)
DIAMETER:	Shoulder 86.3mm / Base 77.6mm
HEIGHT:	312mm ± 1.9mm
LABEL PANEL:	160mm
PUNT DEPTH:	45mm
WEIGHT:	990g
75cl FILL POINT:	67mm
PALLET LOAD:	1,054
LAYERS:	6

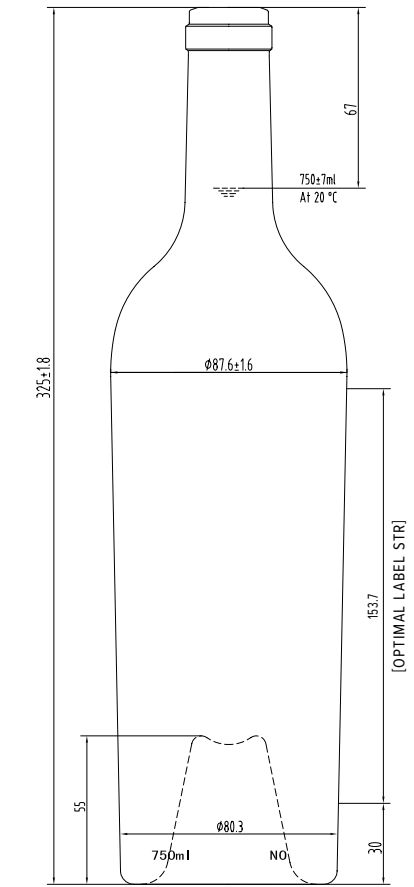

BORDEAUX REPENT (TAPERED)

PRODUCT CODE:	CR5312
MOUTH FINISH:	Cork 32 (Careé)
DIAMETER:	Shoulder 87.6mm / Base 80.3mm
HEIGHT:	325mm ± 1.8mm
LABEL PANEL:	153.7mm
PUNT DEPTH:	55mm
WEIGHT:	1200g
75cl FILL POINT:	67mm
PALLET LOAD:	1,014
LAYERS:	6

THE ART OF THE CAP



MAKE A MARK. LEAVE AN IMPRESSION.



AN ENDING WITH A TWIST

Twelve years ago Chandler's branded Vcap 30H60 closures launched with premium quality wines in mind. Vcap opened up decoration possibilities that were not previously available to New Zealand wine producers. We specialise in all colours & effects for 30x60mm caps.

It was a proud moment when Vcap become New Zealand's second largest wine screwcaps supplier in its seventh year.



Fixed position top-emboss, registered behind top printed decoration.



Hot-foil tipped top embossing.



Tip-printed top embossing on matching matte top and skirt colour.



Skirt embossed of bold decoration elements.



Skirt embossed tip-shaved to expose alloy.

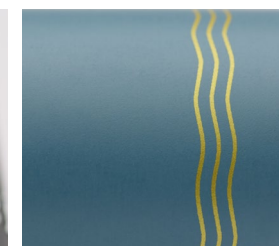

Screen printed decoration on matching matte top and skirt colour.



Detailed Hot-foil skirt decorations.



Skirt off-set printed decoration on metallic side base-coat.

DIVIDED & CONQUERED

Chandler has become one of New Zealand's preferred suppliers of 6 bottle corrugated cardboard Fold-up dividers, 6 & 12 bottle Inter-laced partitions – as well as cost effective Intergard (grey card), stitched 6 & 12 bottle partitions.

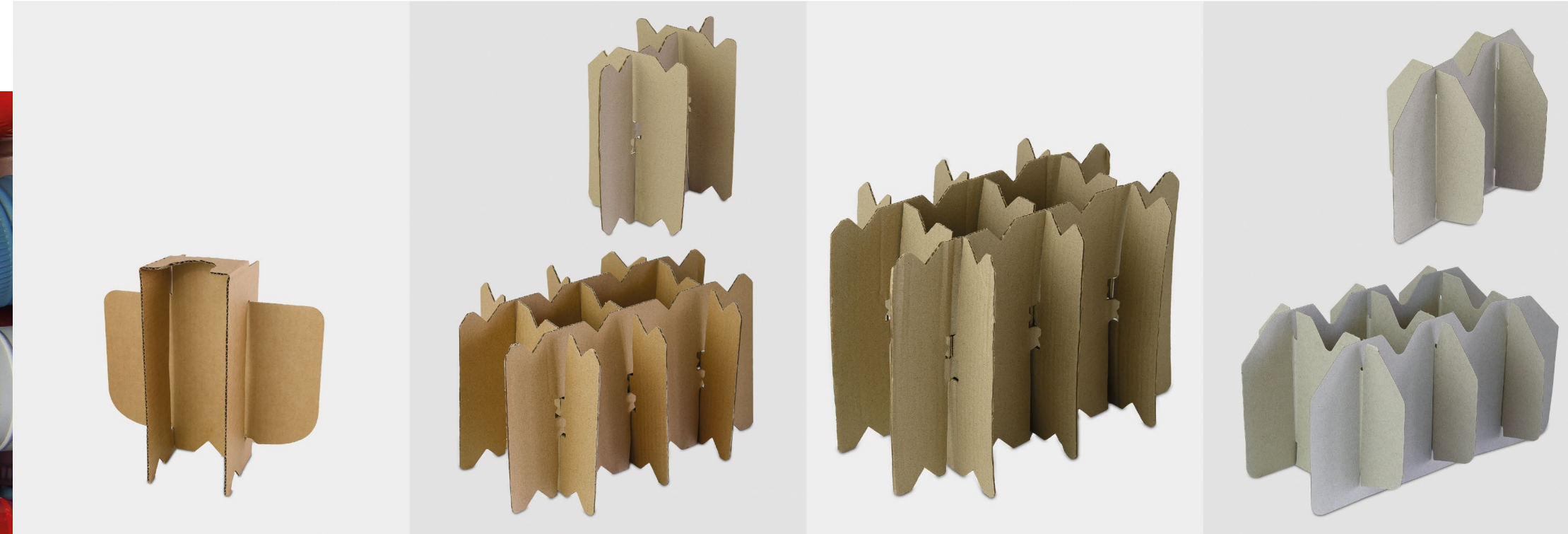

FOLD-UP DIVIDERS

B-Flute corrugate Fold-up partitions with notched locking device for flaps and universal design for most 750ml wine bottle diameters.

Bottles: 6

Thickness: 2.5mm

Heights: 210mm

INTER-LACED DIVIDERS

B-Flute corrugate inter-laced partition sections with notch-cut ends. Universal design with lateral movement to suit all 750ml wine bottle diameters. The 170mm height is cost effective solution for Burgundy & Riesling bottles. The 210mm height is for long bodied Bordeaux style bottles.

Bottles: 6 & 12

Thickness: 2.5mm

Heights: 170mm / 210mm

INTER-LACED DIVIDERS

B-Flute corrugate inter-laced partition sections – North American EXPORT height. Universal design with lateral movement to suit all 750ml wine bottle diameters.

Bottles: 6 & 12

Thickness: 2.5mm

Heights: 298mm

INTERGARD (GREY CARD) DIVIDERS

Intergard (350gsm grey-card) threaded partition. Universal design with lateral movement to suit most 750ml wine bottle diameters. This thin material provides glass separation only – no cushioning effect.

Bottles: 6 & 12

Thickness: 0.9mm

Heights: 160mm / 210mm / 297mm



CHANDLER GLASS & PACKAGING

T: +64 9 448 1288 · E: info@chandler.co
PO Box 303-237, North Harbour,
Auckland 0751, New Zealand.
www.chandler.co

