

# 30x60mm LONG SKIRT CLOSURE

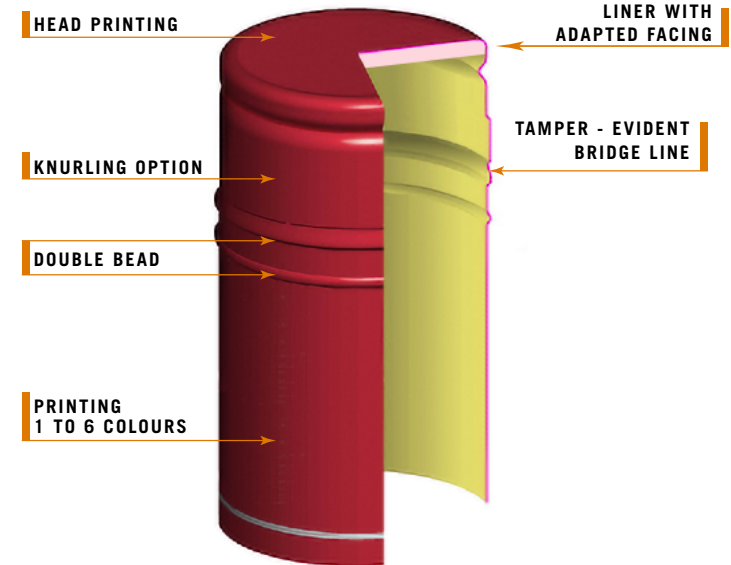
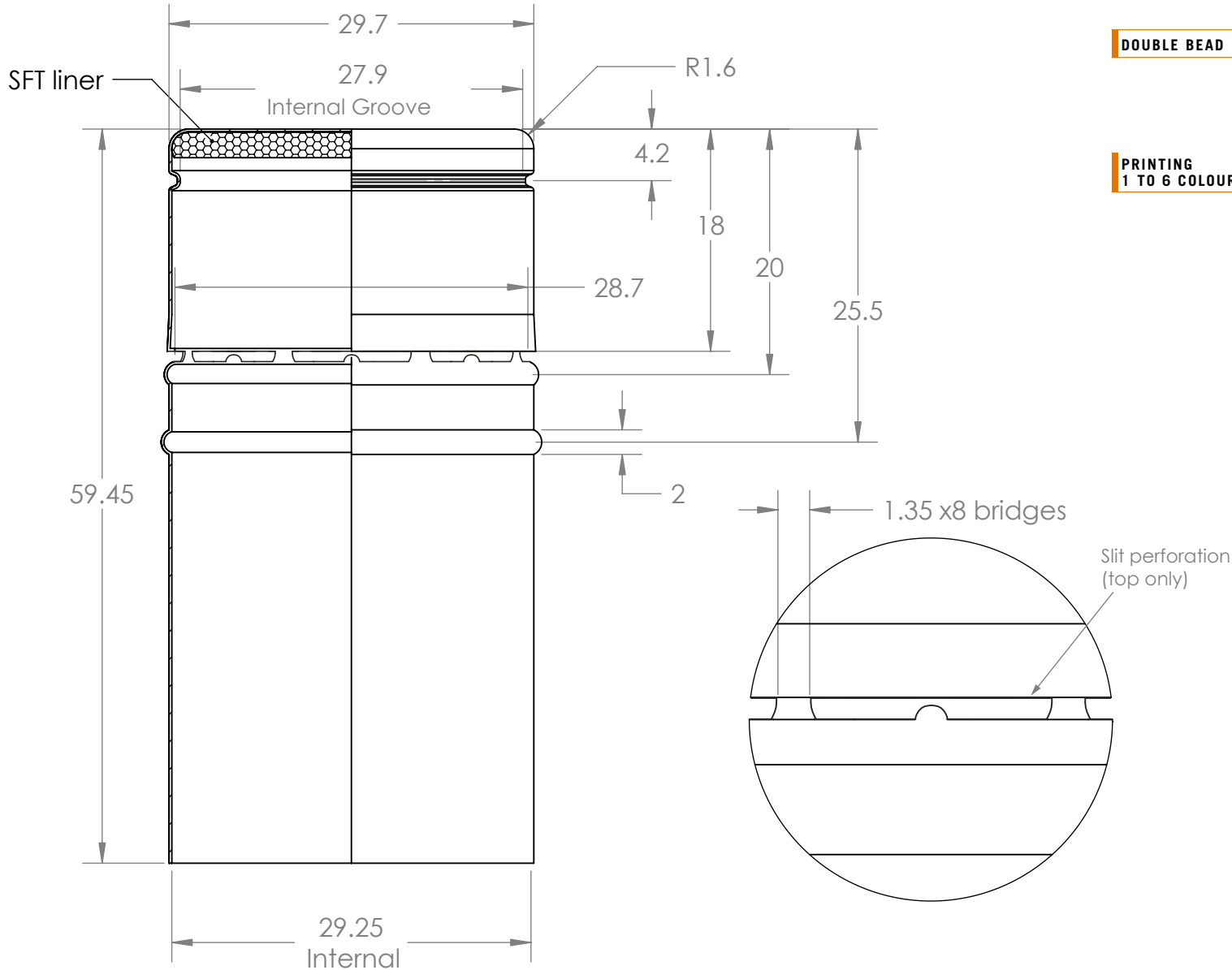

## SPECIFICATION FOR VCAP 30 x 60 CLOSURES

<b>SHELL</b>	30 x 60mm
Material	Alloy 8011
Alloy Gauge	0.23mm
Nominal Weight	4 grams
<b>LINER</b>	Laminated
Material	Saran-film-Tin / Saranex
Manufacturer	Meyer
Thickness	2.1mm
<b>Internal LACQUER</b>	Polyester (FDA approved)
<b>APPLICATION</b>	
Pressure Block Ø	27.5mm
Redraw	1.6mm
Threading Roller Radii	0.75mm
Seaming Roller Radii	min. 0.75mm max. 0.95mm
Threading Roller Setting	7.5 to 13kg
Seaming Roller Setting	6.5 to 12kg
Head Load	160 to 180kg
<b>GLASS FINISH</b>	EN 16293 (BVS 30x60)
<b>TORQUES</b>	Dry mouth finish
Slip Torque	9 to 25 Lbs x inches
Break Torque	8 to 20 Lbs x inches
<b>PACKAGING</b>	Carton: 1,428 pcs
	Export carton
	Polyethylene liner bag