

Burgundy LEGERE

PRODUCT CODE:	CR404
MOUTH FINISH:	BVS 30 x 60
DIAMETER:	80mm ± 1.5mm
HEIGHT:	297mm ± 1.8mm
LABEL PANEL:	100mm
PUNT DEPTH:	19mm
WEIGHT:	420g
75cl FILL POINT:	35mm

NEW ZEALAND

PALLET LOAD:	1,407
LAYERS:	7

AUSTRALIA

PALLET LOAD:	1,771
LAYERS:	7 (3 + 4)

NOTE A: CONTROLLED NECK & MOUTH REFER TO DIMENSIONAL SPECIFICATIONS FOR BVS GLASS MOUTH FINISH Norm: EN16293

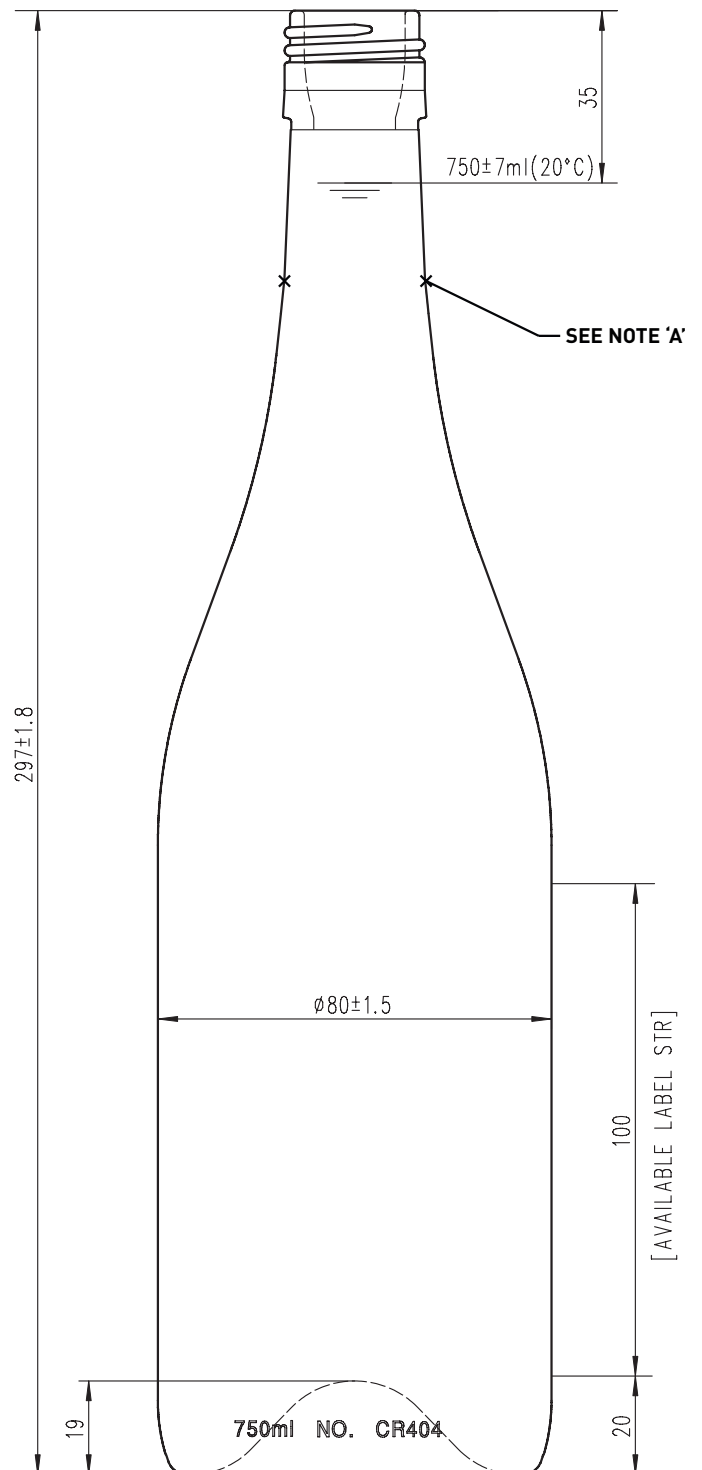

CHANDLER
GLASS & PACKAGING
www.chandler.co

New Zealand & Australia
PO Box 303-237, North Harbour,
Auckland 0751, New Zealand
E: info@chandler.co · T: +64 9 448 1288

Burgundy EXPORT

PRODUCT CODE:	CR403
MOUTH FINISH:	BVS 30 x 60
DIAMETER:	80mm ± 1.6mm
HEIGHT:	298mm ± 1.6mm
LABEL PANEL:	103mm
PUNT DEPTH:	21mm
WEIGHT:	480g
75cl FILL POINT:	35mm

NEW ZEALAND

PALLET LOAD:	1,407
LAYERS:	7

AUSTRALIA

PALLET LOAD:	1,771
LAYERS:	7 (3 + 4)

NOTE A: CONTROLLED NECK & MOUTH REFER TO DIMENSIONAL SPECIFICATIONS FOR BVS GLASS MOUTH FINISH Norm: EN16293

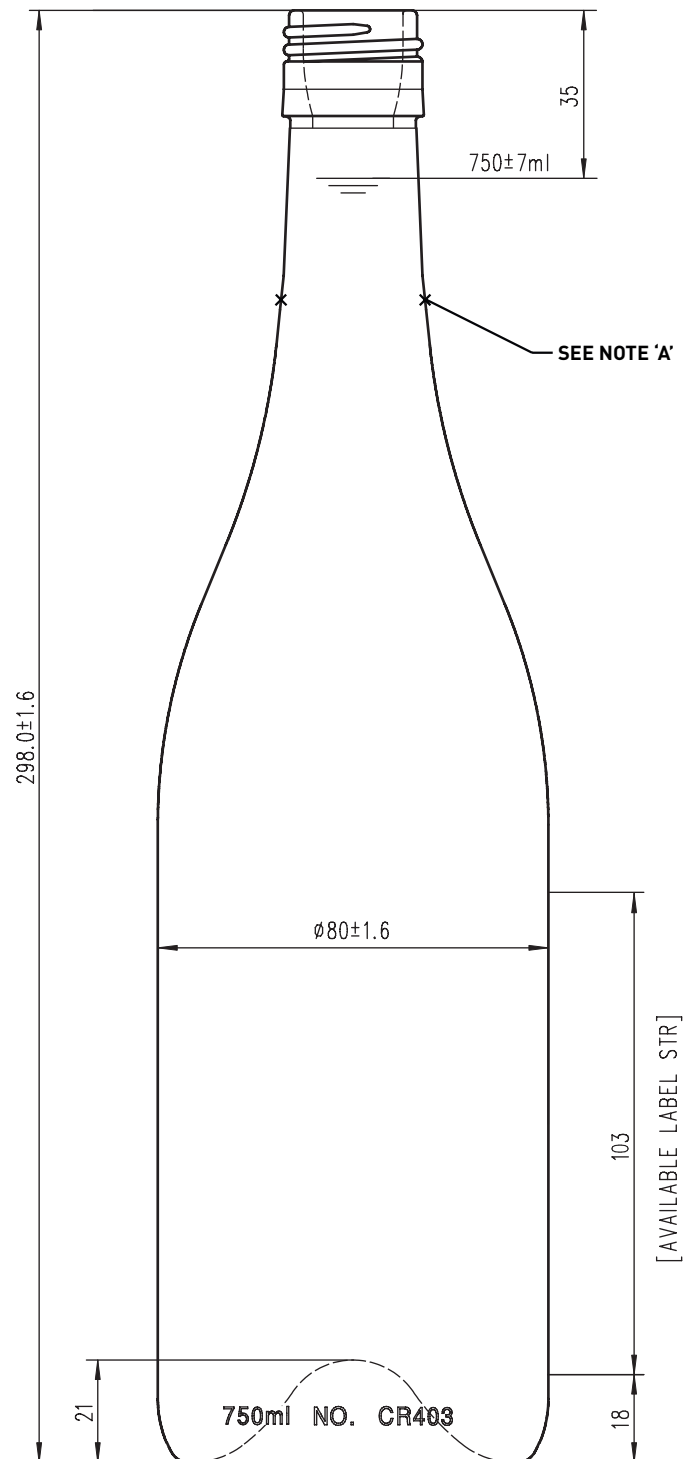

CHANDLER
GLASS & PACKAGING
www.chandler.co

New Zealand & Australia
PO Box 303-237, North Harbour,
Auckland 0751, New Zealand
E: info@chandler.co · T: +64 9 448 1288

Burgundy PREMIER

PRODUCT CODE:	CR408
MOUTH FINISH:	BVS 30 x 60
DIAMETER:	85.8mm ± 1.6mm
HEIGHT:	296mm ± 1.8mm
LABEL PANEL:	83mm
PUNT DEPTH:	35mm
WEIGHT:	555g
75cl FILL POINT:	35mm

NEW ZEALAND

PALLET LOAD:	1,225
LAYERS:	7

AUSTRALIA

PALLET LOAD:	1,554
LAYERS:	7 (3 + 4)

NOTE A: CONTROLLED NECK & MOUTH REFER TO DIMENSIONAL SPECIFICATIONS FOR BVS GLASS MOUTH FINISH Norm: EN16293

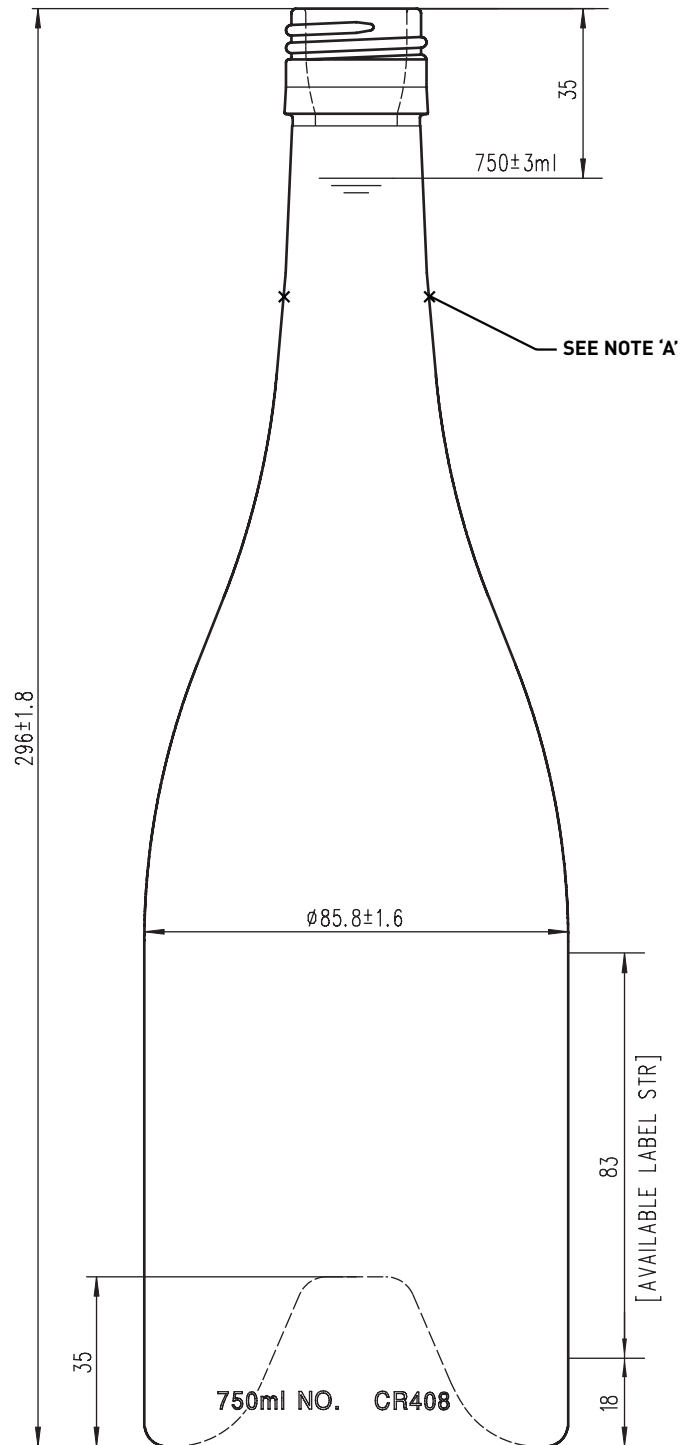

Burgundy TRADITIONAL

PRODUCT CODE:	CR401
MOUTH FINISH:	BVS 30 x 60
DIAMETER:	81.5mm ± 1.5mm
HEIGHT:	298mm ± 1.8mm
LABEL PANEL:	105.5mm
PUNT DEPTH:	29mm
WEIGHT:	555g
75cl FILL POINT:	35mm

NEW ZEALAND

PALLET LOAD:	1,358
LAYERS:	7

AUSTRALIA

PALLET LOAD:	1,729
LAYERS:	7 (3 + 4)

NOTE A: CONTROLLED NECK & MOUTH REFER TO DIMENSIONAL SPECIFICATIONS FOR BVS GLASS MOUTH FINISH Norm: EN16293

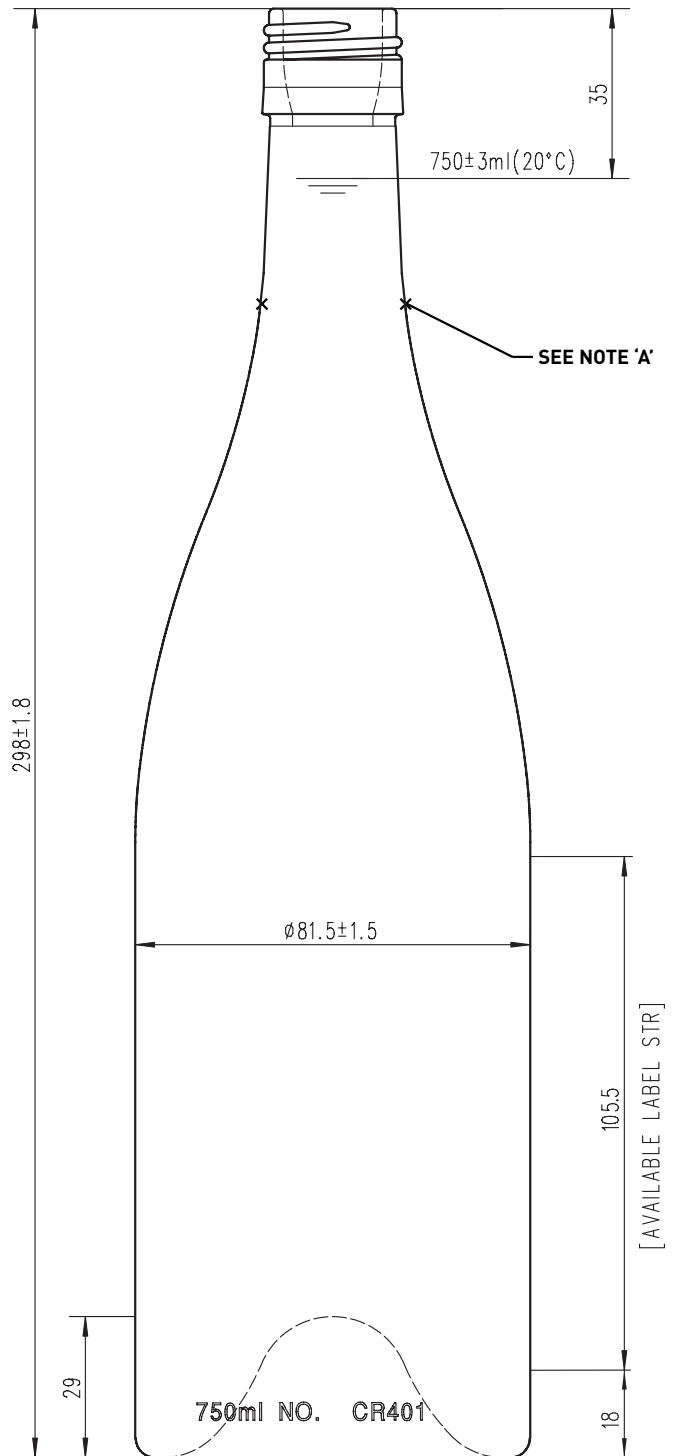

CHANDLER
GLASS & PACKAGING
www.chandler.co

New Zealand & Australia
PO Box 303-237, North Harbour,
Auckland 0751, New Zealand
E: info@chandler.co · T: +64 9 448 1288

Burgundy AVIGNON (Tapered)

PRODUCT CODE:	CR4015
MOUTH FINISH:	BVS 30 x 60
DIAMETER:	Shoulder 87.4mm, Base 80.8mm
HEIGHT:	300mm
LABEL PANEL:	78mm
PUNT DEPTH:	32mm
WEIGHT:	590g
75cl FILL POINT:	35mm

NEW ZEALAND

PALLET LOAD:	1,183
LAYERS:	7

AUSTRALIA

PALLET LOAD:	1,449
LAYERS:	7 (3 + 4)

NOTE A: CONTROLLED NECK & MOUTH REFER TO DIMENSIONAL SPECIFICATIONS FOR BVS GLASS MOUTH FINISH Norm: EN16293

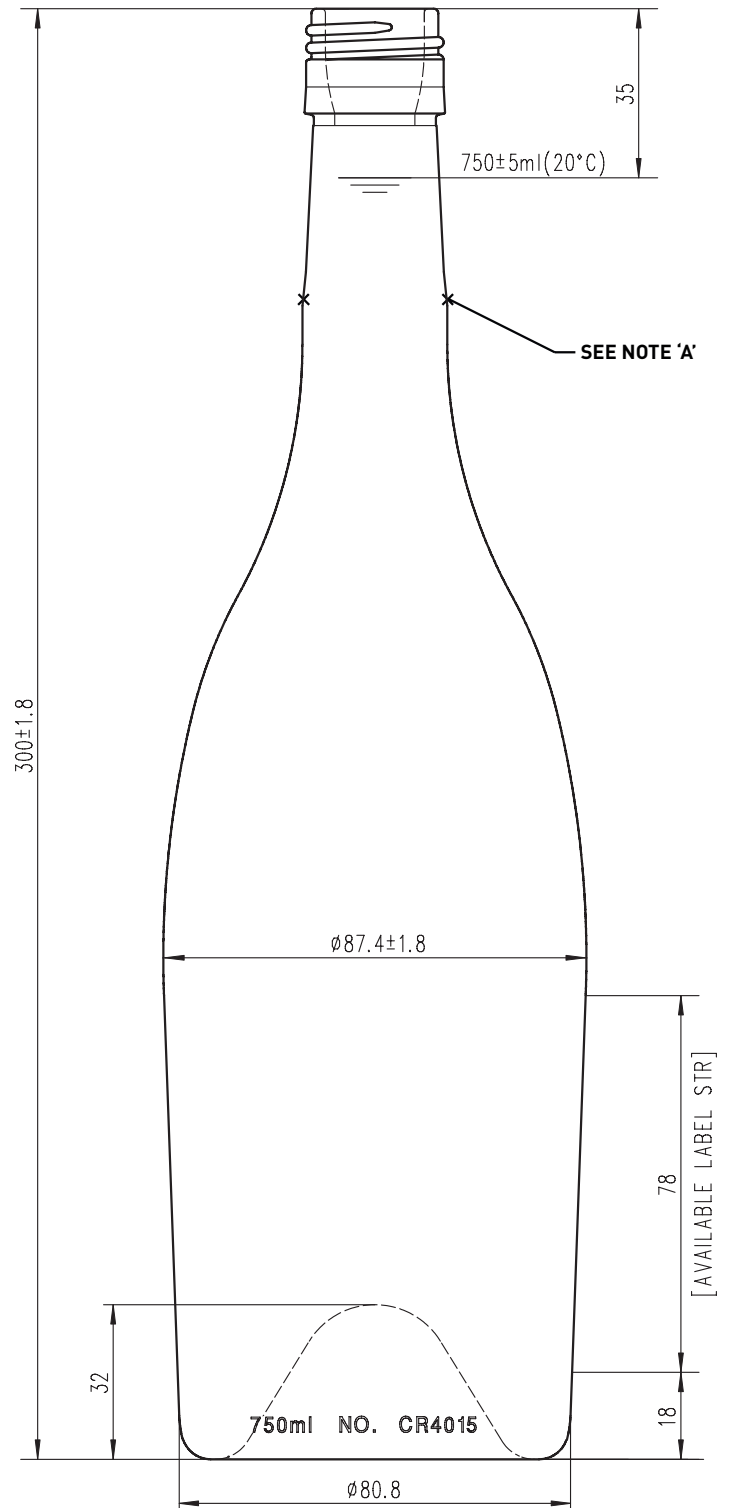

CHANDLER
GLASS & PACKAGING
www.chandler.co

New Zealand & Australia
PO Box 303-237, North Harbour,
Auckland 0751, New Zealand
E: info@chandler.co · T: +64 9 448 1288

Burgundy GRANDEUR

PRODUCT CODE:	CR409
MOUTH FINISH:	BVS 30 x 60
DIAMETER:	87mm ± 1.6mm
HEIGHT:	298mm ± 1.8mm
LABEL PANEL:	87.5mm
PUNT DEPTH:	38mm
WEIGHT:	675g
75cl FILL POINT:	35mm

NEW ZEALAND

PALLET LOAD:	1,225
LAYERS:	7

AUSTRALIA

PALLET LOAD:	1,554
LAYERS:	7 (3 + 4)

NOTE A: CONTROLLED NECK & MOUTH REFER TO DIMENSIONAL SPECIFICATIONS FOR BVS GLASS MOUTH FINISH Norm: EN16293

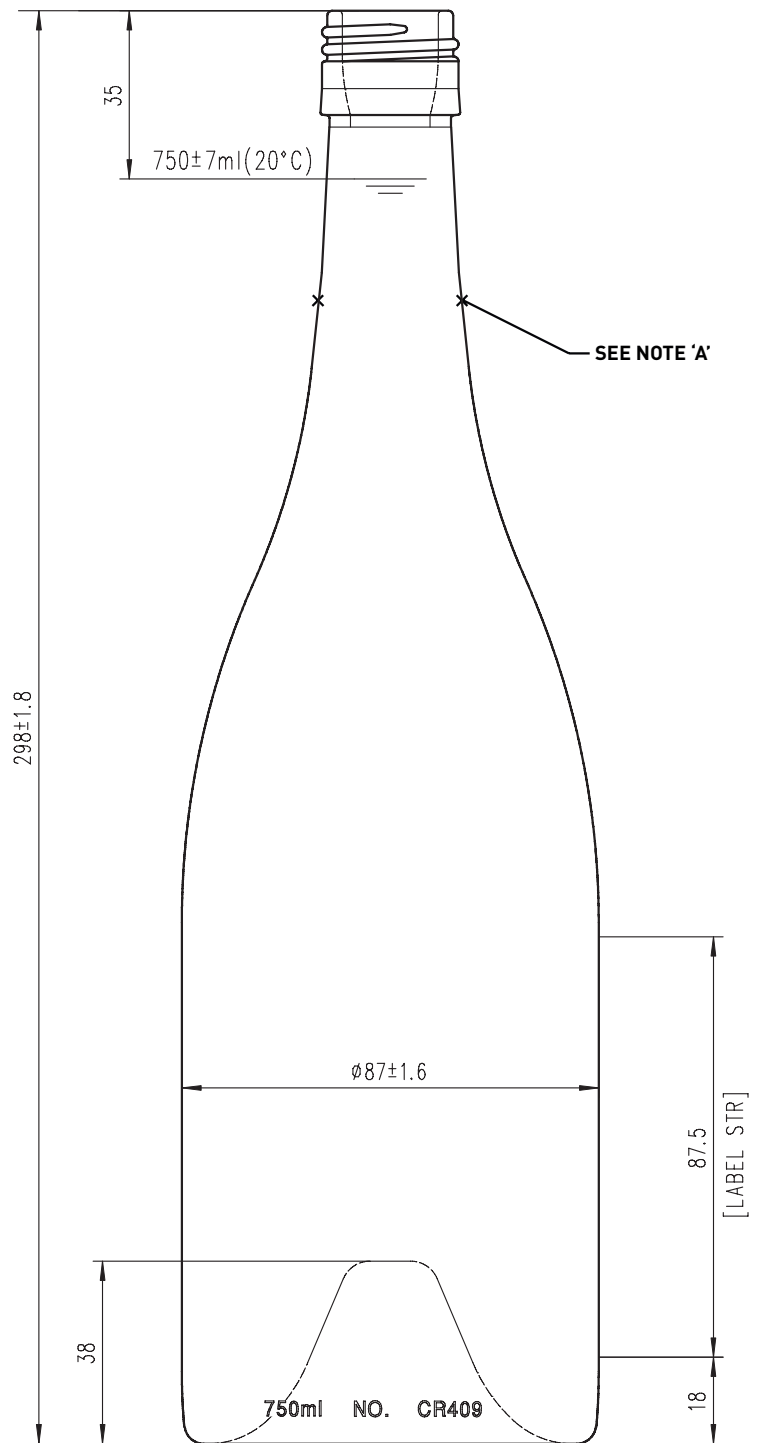

CHANDLER
GLASS & PACKAGING
www.chandler.co

New Zealand & Australia
PO Box 303-237, North Harbour,
Auckland 0751, New Zealand
E: info@chandler.co · T: +64 9 448 1288

Burgundy PASSION

PRODUCT CODE:	CR407
MOUTH FINISH:	BVS 30 x 60
DIAMETER:	88.0mm \pm 1.6mm
HEIGHT:	299mm \pm 1.8mm
LABEL PANEL:	90mm
PUNT DEPTH:	45mm
WEIGHT:	800g
75cl FILL POINT:	30mm

NEW ZEALAND

PALLET LOAD:	1,183
LAYERS:	7

AUSTRALIA

PALLET LOAD:	1,505
LAYERS:	7 (3 + 4)

NOTE A: CONTROLLED NECK & MOUTH REFER TO DIMENSIONAL SPECIFICATIONS FOR BVS GLASS MOUTH FINISH Norm: EN16293

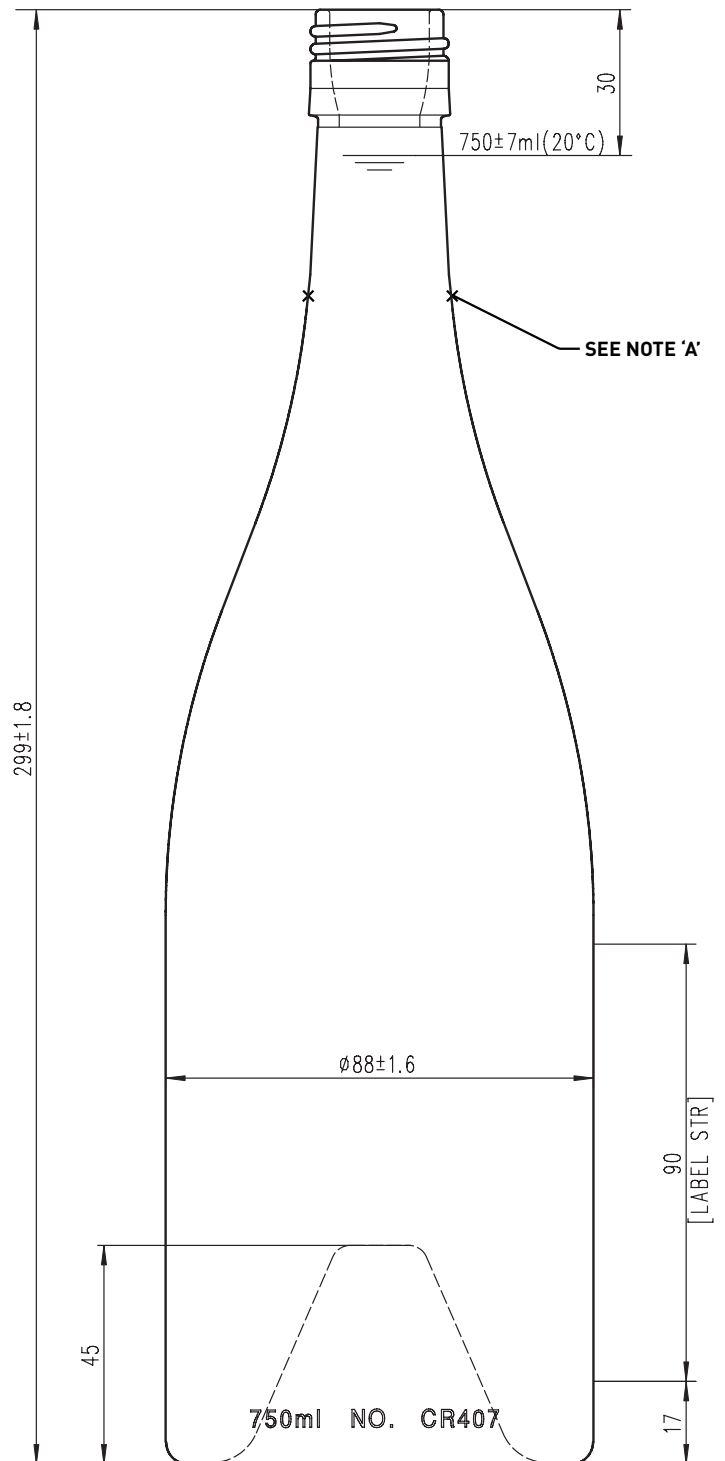

CHANDLER
GLASS & PACKAGING
www.chandler.co

New Zealand & Australia
PO Box 303-237, North Harbour,
Auckland 0751, New Zealand
E: info@chandler.co · T: +64 9 448 1288

Burgundy ALBA

PRODUCT CODE:	CR40028
MOUTH FINISH:	BVS 31.5 x 60
DIAMETER:	86.2mm ± 1.8mm
HEIGHT:	306mm ± 1.8mm
LABEL PANEL:	88mm (Ø5.5mm heel)
PUNT DEPTH:	41mm
WEIGHT:	820g
75cl FILL POINT:	30mm

NEW ZEALAND

PALLET LOAD:	1,183
LAYERS:	7

AUSTRALIA

PALLET LOAD:	1,512
LAYERS:	7 (3 + 4)

NOTE A: CONTROLLED NECK & MOUTH REFER TO DIMENSIONAL SPECIFICATIONS FOR BVS GLASS MOUTH FINISH Norm: EN16293

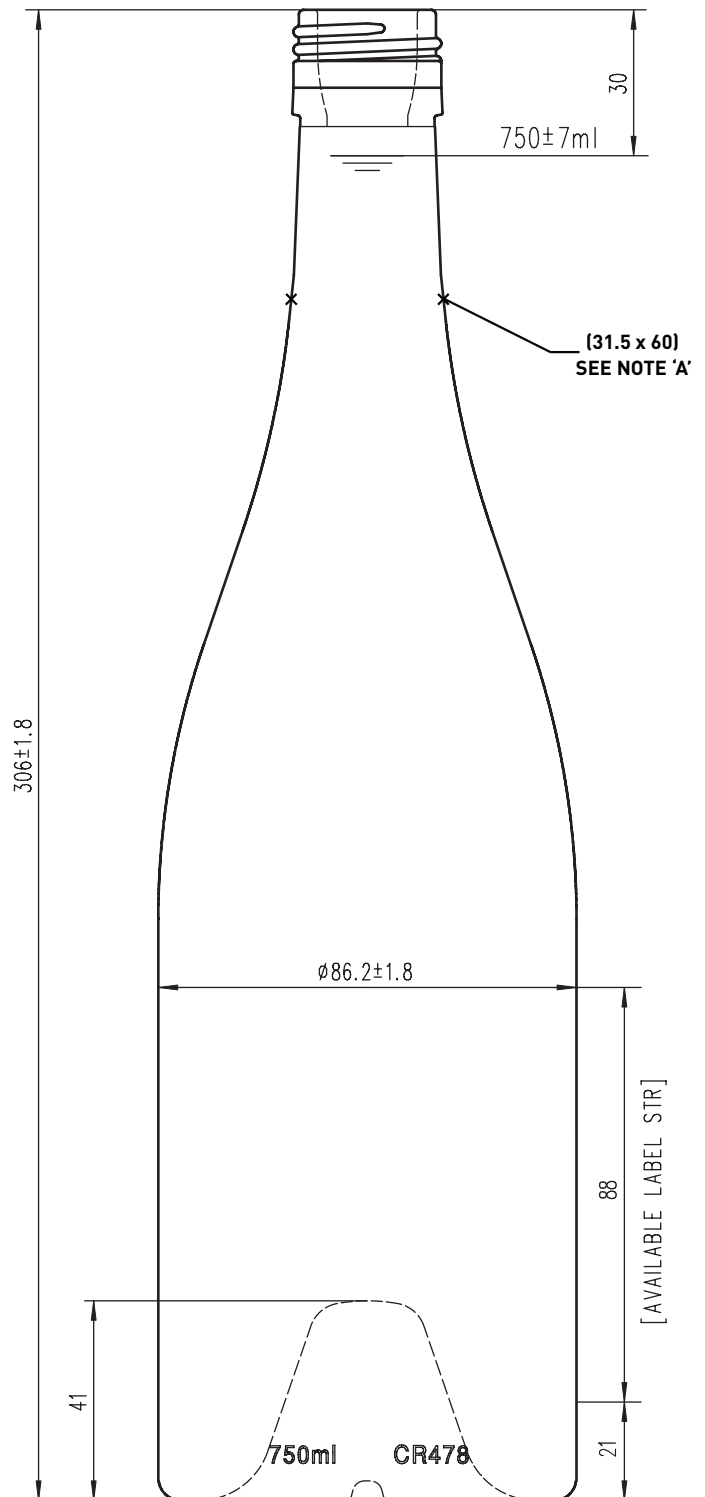

Burgundy PRESTIGE (Magnum)

PRODUCT CODE:	CR4021
MOUTH FINISH:	BVS 30 x 60
DIAMETER:	106.55mm ± 1.8mm
HEIGHT:	345mm ± 1.8mm
LABEL PANEL:	114.8mm
PUNT DEPTH:	36mm
WEIGHT:	880g ± 30g
75cl FILL POINT:	45mm

NEW ZEALAND

PALLET LOAD:	315
LAYERS:	3

AUSTRALIA

PALLET LOAD:	822
LAYERS:	6 (3 + 3)

NOTE A: CONTROLLED NECK & MOUTH REFER TO DIMENSIONAL SPECIFICATIONS FOR BVS GLASS MOUTH FINISH Norm: EN16293

